



HOISTS FOR EVERY SPACE

TL4.00HDI (9KOH) INSTALLATION / OWNERS MANUAL

TWO POST HOIST

Capacity: 4 TONNE

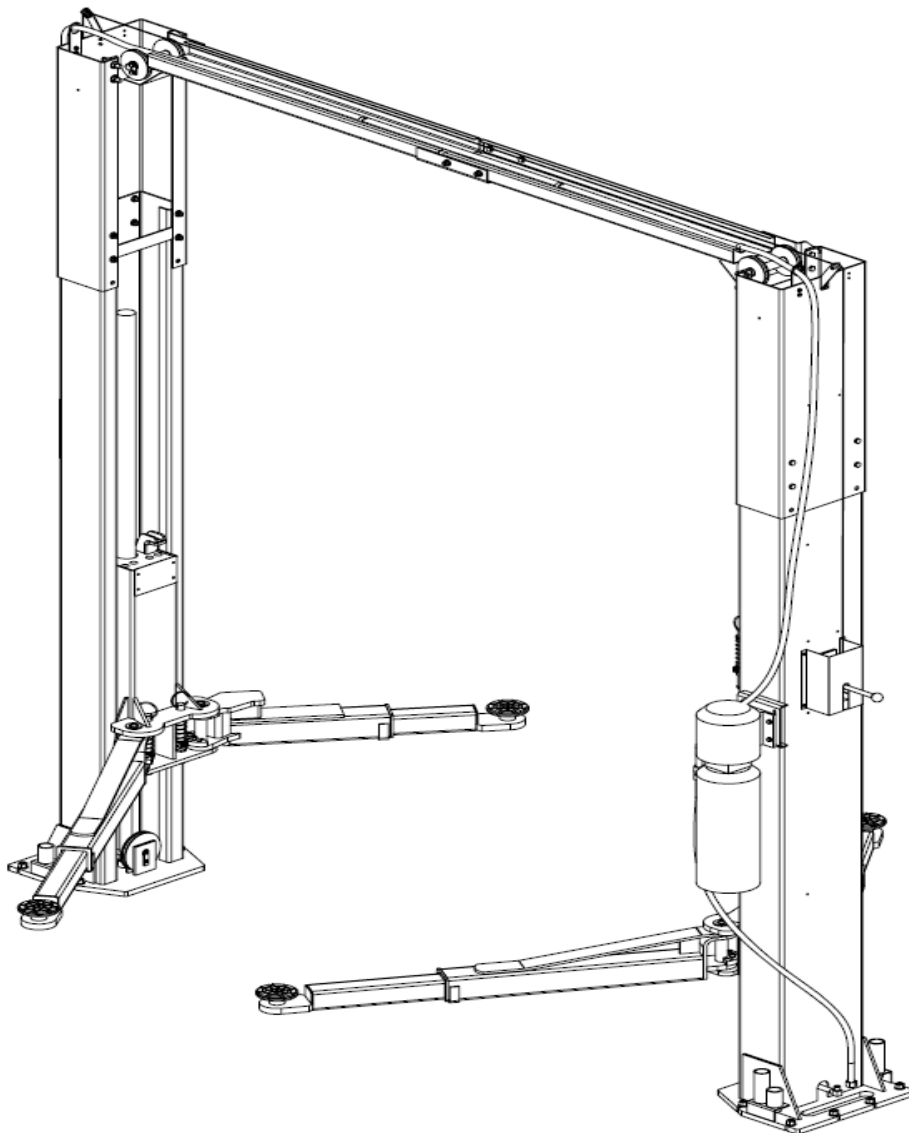

Read this manual thoroughly before installing, operating, or maintaining this lift. When done with installation be sure to return documents to package and give all materials to lift owner/operator. When installation is complete be sure to run lift up and down a few cycles with and without “typical” vehicle loaded on lift.

TABLE OF CONTENTS

• IMPORTANT INFORMATION.....	2
• GENERAL LIFT INFORMATION / FEATURES.....	2
• LIFT SPECIFICATIONS.....	3
• LIFT AREA LAYOUT INFORMATION.....	5
• FOUNDATION and ANCHORING REQUIREMENTS.....	6
• TOOLS and EQUIPMENT REQUIRED for INSTALL.....	7
• INSTALLATION PROCEDURE.....	7
• LIFT LOCKOUT/TAGOUT.....	11
• LIFT OPERATION.....	12
• SAFETY PROCEDURES.....	13
• PREVENTIVE MAINTENANCE SCHEDULE.....	13
• TROUBLESHOOTING.....	15
• ILLUSTRATED PARTS BREAKDOWN.....	16
• PARTS LIST.....	17
• WARRANTY.....	20

IMPORTANT INFORMATION

Two Post Lifts

1. Any freight damage must be noted on the freight bill before signing and reported to the freight carrier with a freight claim established. Identify the components and check for shortages. If shortages are discovered, please contact the Distributor / Sales Rep. in your area for service.
2. Consult building owner and / or architect's plans when applicable to establish the best lift location. The lift should be located on a relatively level floor with 4 in. (102mm) minimum thickness, 3000-psi concrete slab that has been properly cured. **There can be no cracks in the slab within 36 in. (914mm) of the base plate location, and no seams in the foundation within 6 in. (152mm) of its location! Remember: any structure is only as strong as the foundation on which it is located!**

IMPORTANT! Make sure you have extra help or heavy duty lifting equipment when unloading and assembling the lift.

3. Please read the safety procedures and operating instructions in this manual before operating lift. Keep this manual near lift at all times. Make sure all operators read this manual.
4. The lift should be located on a relatively level floor of less than 3 degrees slope. If slope is questionable, consider a survey of the site and/or the possibility of pouring a new level concrete slab.
5. Make sure you have enough area and ceiling height to install lift. (See Lift Specifications)
6. Never raise a car until you have double checked all bolts, nuts and hose fittings.
7. Always lower the lift onto the locks before going under the vehicle. Never allow anyone to go under the lift when raising or lowering.

This is a vehicle lift installation/operation manual and no attempt is made or implied herein to instruct the user in lifting methods particular to an individual application. Rather, the contents of this manual are intended as a basis for operation and maintenance of the unit as it stands alone or as it is intended and anticipated to be used in conjunction with other equipment.

Proper application of the equipment described herein is limited to the parameters detailed in the specifications and the uses set forth in the descriptive passages. Any other proposed application of this equipment should be documented and submitted in writing to the factory for examination. The user assumes full responsibility for any equipment damage, personal injury, or alteration of the equipment described in this manual or any subsequent damages.

CAUTION!!

ENSURE THAT ALL CABLE SHEAVES, BEARINGS, AND SHAFTS ARE SUFFICIENTLY LUBRICATED. ALSO, THE CORNERS OF EACH COLUMN SHOULD BE LIGHTLY GREASED WITH QUALITY TYPE LITHIUM GREASE PRIOR TO OPERATING THE LIFT. LUBRICATE ALL ON AN ANNUAL BASIS.

Motors and all electrical components are not sealed against the weather and moisture. Install this lift in a protected indoor location. Failure by the owner to provide the recommended shelter could result in unsatisfactory lift performance, property damage, or personal injury.

This lift is an 9,000 lb. (4 tonne) capacity, 2-Post Lifts. The locking latch system is very similar to an extension ladder. The locking latch is in contact with the latch rack. As the lift rises the locking latch drops into place. The locking latch engages in latch rack in 3" (76.2mm) increments starting at about 16" (406.4mm) from the ground. The locking latches must be manually disengaged for the lift to lower. The locking latch is released by pulling the Release Cable raising the latch up off the latch rack. Once the raise button is pressed, the latch will automatically reengage after approximately 3" (76.2mm) of travel. Heavy bearings and heavy-duty leaf chains are used throughout the lift. The work is done with the heavy-duty chain connected to a 2-1/2" (63.5mm) cylinder, driven by an electric / hydraulic pump.

LIFT SPECIFICATIONS

Capacity	9,000 lbs. (4 tonne) 2,250 lbs per Arm (1.02 tonne per Arm)
Rise Time	60 Seconds
Overall Height	142" (3607mm)
Overall Floor Width	134-1/4" (3410mm)
Maximum Lift Height	74" (1880mm) with adapters 80-1/2 (2045mm)
Minimum Pad Height	4" (102mm)
Between Columns	109-3/4" (2788mm)
Column Size	7-1/4" x 11-1/8" (184mm x 283mm)
Drive Thru	101.54" (293.12mm)
Motor	2HP, 208 - 230 VAC, 1PH

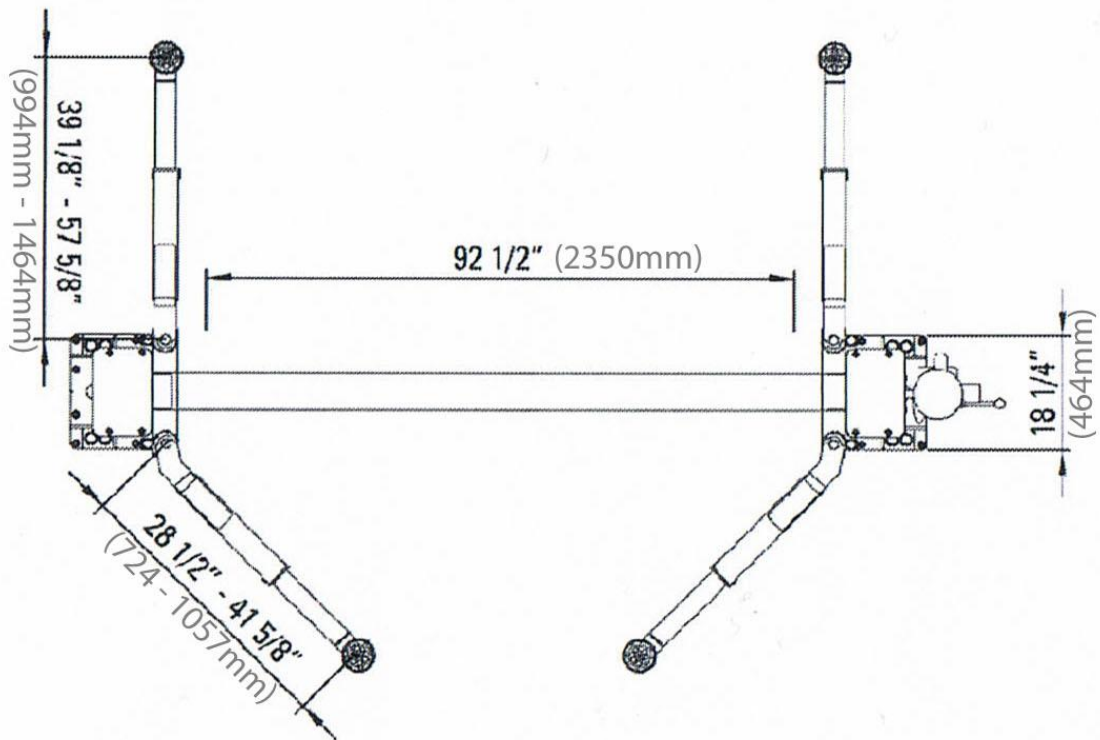
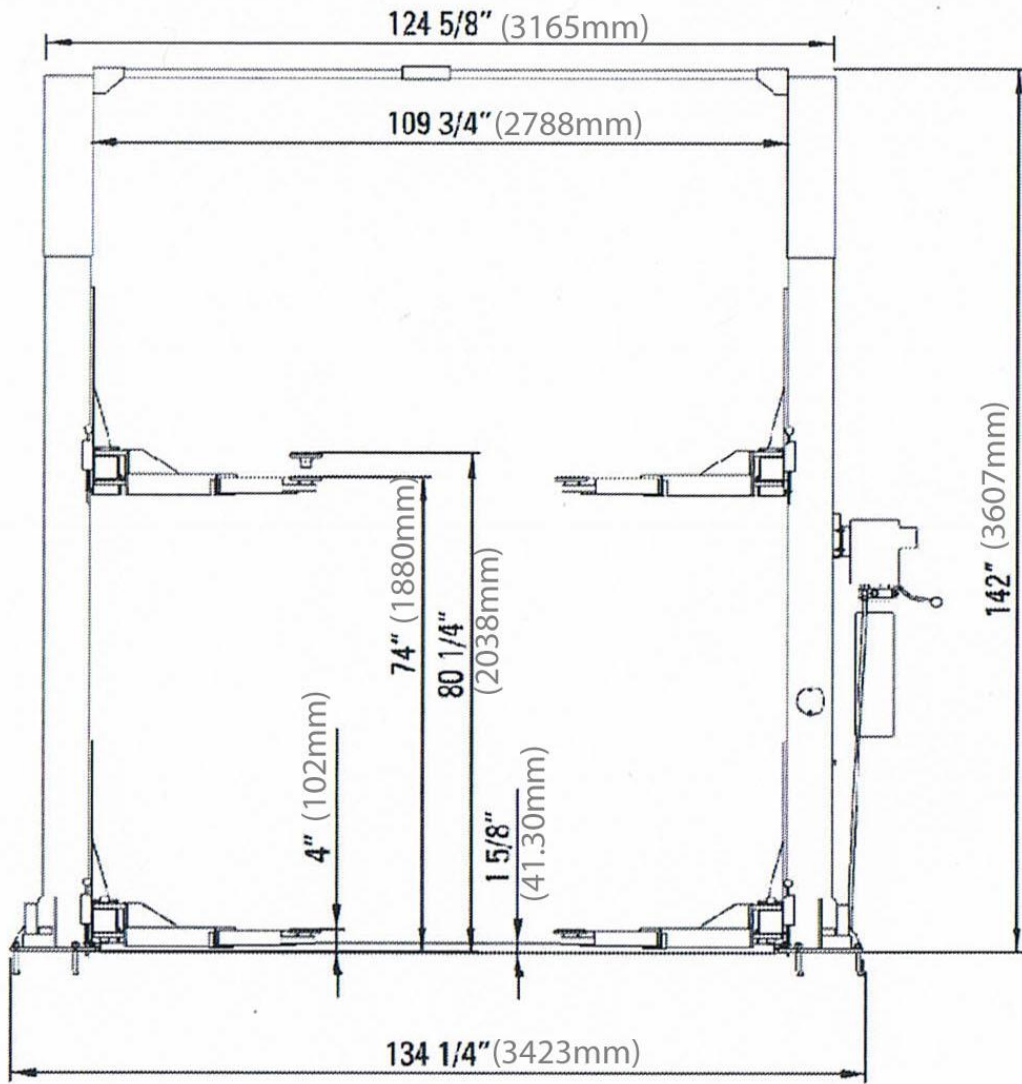

LIFT AREA LAYOUT INFORMATION

OVERHEAD
MODEL
(Asymmetrical Arm configuration)

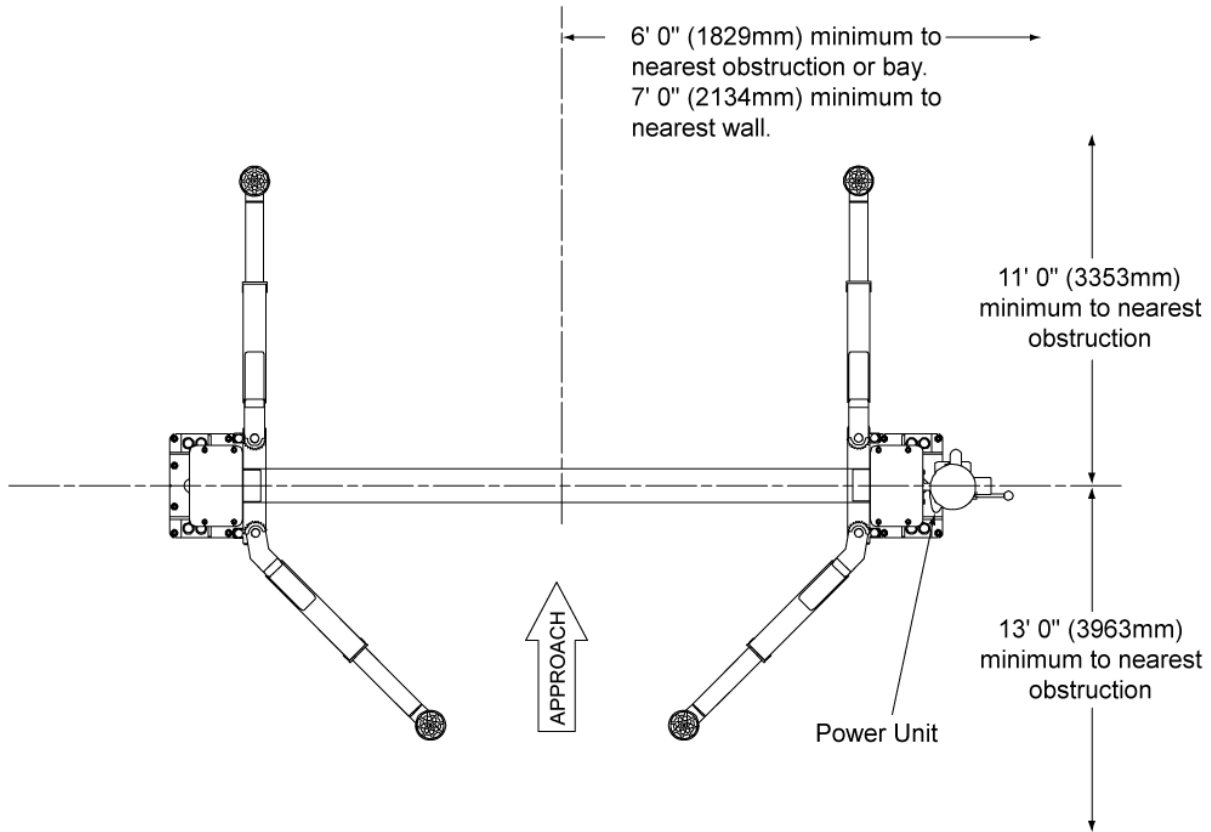

NOTE: Lift can be installed so power unit can column can be located on either side. However to save operation steps it is recommended that it is placed on passenger side of lift.

FOUNDATION and ANCHORING REQUIREMENTS

1. Concrete shall have compression strength of at least 3,000 PSI and a minimum thickness of 4" (102mm) in order to achieve a minimum anchor embedment of 3 1/4" (83mm). NOTE: When using the standard supplied 3/4" x 5-1/2" (19mm x 140mm) long anchors; if the top of the anchor exceeds 2 1/4" (57mm) above the floor grade, you DO NOT have enough embedment.
2. Maintain a 6" (152mm) minimum distance from any slab edge or seam. Hole to hole spacing should be a minimum 6 1/2" (165mm) in any direction. Hole depth should be a minimum of 4" (102mm).

CAUTION!!

3. DO NOT install on asphalt or other similar unstable surface. Columns are supported only by anchoring to floor.
4. Using the horseshoe shims provided, shim each column base as required until each column is plumb. If one column has to be elevated to match the plane of the other column, full size base shim plates should be used. Torque anchors to 85 ft-lbs (115.2nm). Shim thickness MUST NOT exceed 1/2" (13mm) when using the 5 1/2" (140mm) long anchors provided with the lift. Adjust the column extensions plumb.
5. If anchors do not tighten to 85 ft-lbs (115.2nm). installation torque, replace the concrete under each column base with a 4' x 4' x 6" (1219 x 1219 x 152mm) thick 3,000 PSI minimum concrete pad keyed under and flush with the top of existing floor. Allow concrete to cure before installing lifts and anchors (typically 2 to 3 weeks).

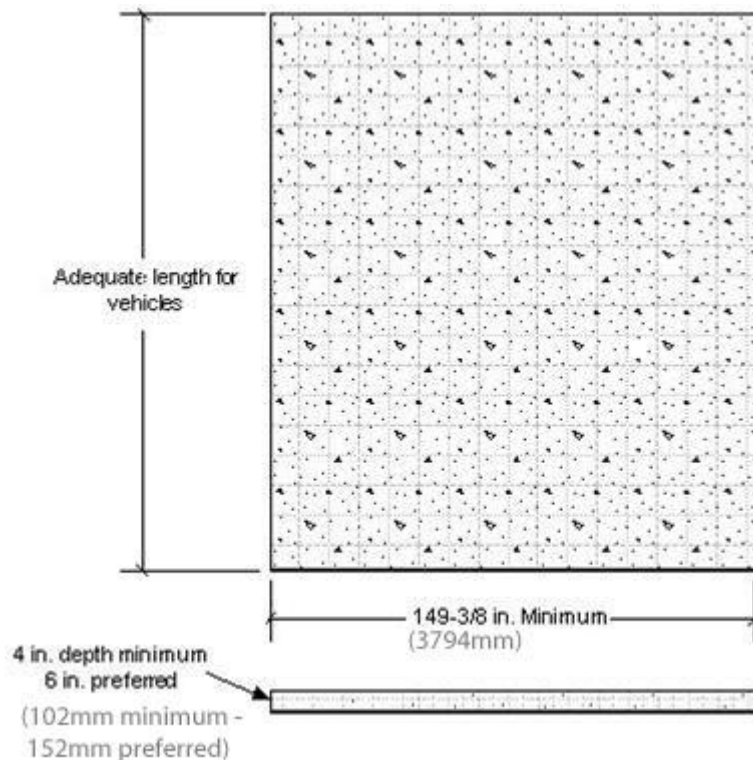

TOOLS REQUIRED FOR INSTALL

The installation of this lift is relatively simple and can be accomplished by two men in a few hours. The following tools and equipment are needed:

- Hoist or Forklift (optional)
- Two 10' - 12' (3 - 3.5m) step ladders
- ISO 32 Light Hydraulic Oil (approx. 12 quarts / 11.41lt)
- Tape Measure
- 4' (1219mm) Level
- Rotary Hammer Drill with 3/4 in. (19mm) Drill Bit
(Core Drill Rebar Cutter recommended)
- Metric Sockets and Open Wrench set
- Vise grips
- 8mm Socket Head Wrench
- Torque wrench with 1-1/8" (29mm) socket anchors
- Teflon Tape

INSTALLATION PROCEDURE

- STEP 1.** After unloading the lift, place it near the intended installation location.
- STEP 2.** Remove the shipping bands and packing material from the lift. The power unit and cylinders will be unpacked from the top.
- STEP 3.** Open the wrapping from the upper column and carefully remove the parts from inside. Unbolt the column from the shipping brackets. Unbolt the up-rights from the columns and assemble it to the column.
- STEP 4.** Remove the packing brackets and bolts holding the two columns together (do not discard bolts; they are used in the assembly of the lift).
- STEP 5.** Once the power unit column location is decided, insure that the proper lift placement is observed from walls and obstacles. Also check the ceiling height for clearance in this location.
NOTE: the power unit column can be located on either side. It is helpful to try and locate the power side with the passenger side of the vehicle when loaded on the lift to save steps during operation.
- STEP 6.** Unpack the cylinders and open the oil port on each cylinder by unscrewing the black plastic cap. Move the carriage up about 20" to 25" (508 – 635mm). Next, carefully slide the cylinder inside from the bottom of the carriage. The oil port will face the backside of the column and the notch on the bottom of the cylinder will fit into the hole in the center of the base plate.
- STEP 7.** Position the columns facing each other 107-1/4" (2724mm) inside base plates. Square the columns by measuring diagonally from the corner points on the base plates (within 1/4" (6.35mm)).

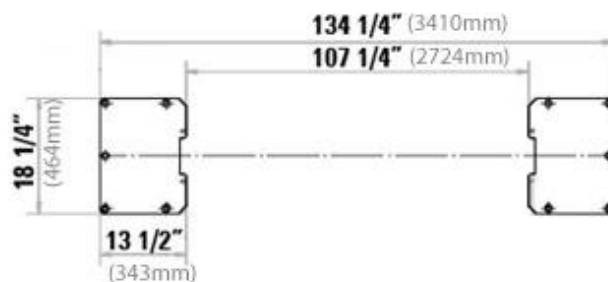

- STEP 8.** Use the existing holes in column base plate as a guide for drilling the 3/4" (19mm) diameter holes into the concrete. Drill the anchor holes only for ONE column, installing anchors as you go. You will install anchors in second column after the cables, hoses, and cross beam are installed.

NOTE: Drilling thru concrete slab (recommended) will allow the anchor to be driven thru the bottom of slab, if the threads are damaged or if the lift will need to be relocated.

CAUTION!!

Anchors must be at least 6" (152mm) from the edge of the slab or any seam.

1. Use a concrete hammer drill with a carbide tip, solid drill bit the same diameter as the anchor, 3/4". (.775 to .787 inches diameter). Do not use excessively worn bits or bits which have been incorrectly sharpened.
2. Keep the drill in a perpendicular line while drilling.
3. Let the drill do the work. Do not apply excessive pressure. Lift the drill up and down occasionally to remove residue to reduce binding.
4. Drill the hole to depth equal to the length of anchor.
Note: Drilling thru concrete (recommended) will allow the anchor to be driven thru the bottom of foundation if the threads are damaged or if the lift will need to be relocated.
5. For better holding power blow dust from the hole. Place a flat washer and hex nut over threaded end of anchor, leaving approximately 1/2" (12.7mm) of thread exposed carefully tap anchor. Do not damage threads. Tap anchor into the concrete until nut and flat washer are against base plate. Do not use an impact wrench to tighten! Tighten the nut, two or three turns on average concrete (28-day cure). If the concrete is very hard only one or two turns may be required. Check each anchor bolt with torque wrench set to 85 foot pounds.

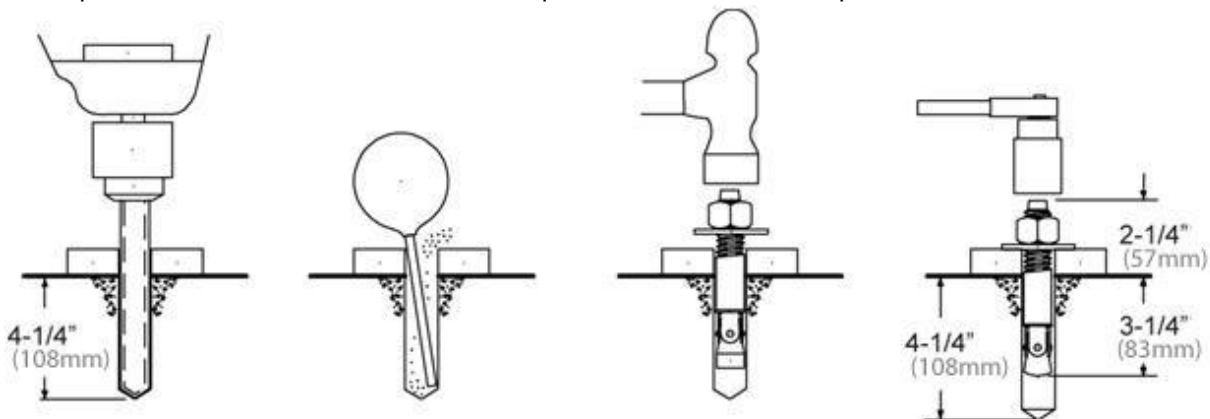

Drill holes using 3/4" (19.05mm) carbide tipped masonry drill bit per ANSI standard B94.12.1977

Clean hole.

Run nut down just below impact section of bolt. Drive anchor into hole until nut and washer contact base.

Tighten nut with Torque wrench to 85 ft.-lbs (115.2nm).

STEP 9. Using a level, check column for side-to-side plumb and front-to-back plumb. If needed, use horseshoe shims provided by placing shims underneath the base plate and around the anchor bolt. This will prevent bending the column bottom plates (Shim thickness should not exceed 1/2" (12.7mm)). Tighten 3/4" (19.05mm) anchor bolts to **85 ft.-lbs. (115.2nm)** of torque.

STEP 10. Using a tape measure, measure from corner of the base on main side column to the opposite corner of the offside column to insure legs are square (within a 1/4" (6.35mm)).

STEP 11. Set carriages on the first safety latch engagement. Be sure each carriage is at the same height by measuring from the top of the base to the bottom of the carriage (double check the latches before working under the carriages). This dimension should be within 1/4" (6.35mm).

STEP 12. Installing the equalizing cables: for general cable arrangement. Route the first cable as shown on next page. Tighten nut on one cable stud so that the end of stud passes the nylon on the nut. Pull the other end of cable and run nut on it. Repeat above for second cable.

NOTE: DO NOT tighten cables at this time. Just start them on the threads. Other column will be anchored in later steps. If you tighten cables at this time you will pull the column and be unable to properly level/shim it for anchor installation.

STEP 13. Install the overhead cross beam. This cross beam has two pieces to be connected by five (5) bolts in the center of the beam. Be sure to bolt them together by installing the bolts from inside the cross beam out. This is to avoid interference with the cable when operating the lift. Next, install the cross beam between two columns.

STEP 14. After fastening the cross beam, check and confirm that the remaining column is plumb.

STEP 15. Secure the remaining column by duplicating STEP 6 and STEP 7.

STEP 16. Mount the power unit on the main side leg to the power unit bracket using the four 5/16" (7.93mm) bolts and nuts. Connect the power unit to the fitting installed on the back of the main leg using a short hose supplied.

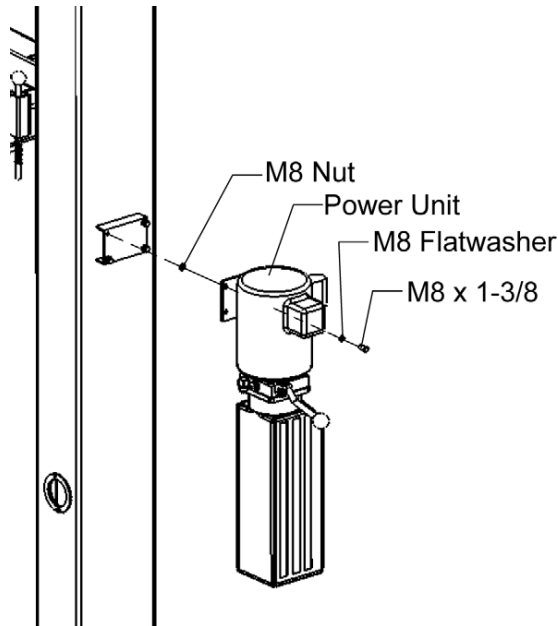

STEP 17. Connect the equalizing cables. Do not tighten as this stage of assembly.

NOTE: The cable stud that connects to the from right corner of the carriage should be connected first by pulling the stud through the carriage hole and up where it is easy to be held by locking pliers. Pull the stud back into place after threading at least 1/2" (12.7mm) of the stud past the locknut. Connect the other ends to the rear right corners of the carriage with at least 1/2" (12.7mm) of thread showing past the lock nut (cables run on the inside of the carriage). It may be necessary to manually raise both carriages above the cylinder to provide enough space to use the locking pliers. Make sure the carriage is set in the LOCK position.

STEP 18. Adjust the carriage cable tension. This is accomplished by tightening the carriage adjustment nut on the top of each carriage. The rear carriage adjustment nut adjusts the opposite post carriage height. The left post carriage nut adjusts the right column carriage, and the right column carriage nut adjusts the left column carriage. Adjust each cable to approximately 1/2" (12.7mm) side-to-side play.

STEP 19. Cylinder centering and chain installation: Make sure the "Tip" on the bottom of the cylinder is properly located into the center hole on top of the cylinder mount in base. Pull the pre-attached leaf chain in both sides up and over the chain sheave on top of the cylinders.

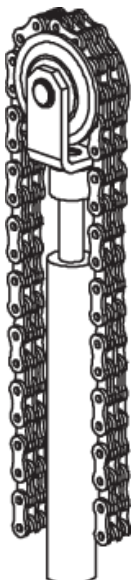

- STEP 20.** Connect the Hydraulic Hoses and Fittings.
- STEP 21.** Install remaining anchors at this point using directions from page 8.
- STEP 22.** Install the swing arms on the carriages using the included 1-1/2" (38.1mm) diameter pins. Check for proper engagement of the arm lock – the rack on the lock should fully engage the gear on the arm. Note you may have to loosen the arm lock bolts to get proper engagement and to install the arm pins. BE SURE to retighten the lock bolts after the arm pins are installed.
- STEP 23.** Adjust the carriage cables tension. Adjust each cable to approximately 1/2" (12.7mm) side-topside play. Check the latch releases to insure the carriage is still sitting on the appropriate latch.
- STEP 24.** Remove the vent plug from the power unit and fill the reservoir. Use a Ten Weight (ISO AW32) non-foaming, non-detergent hydraulic fluid (i.e. Texaco HD32 or equal). The unit will hold approximately twelve quarts of fluid.
- STEP 25.** Make the Electrical hookup to the power unit; 220V Single Phase. It is recommended that a 220 Volt, 30 Amp twist lock plug be installed in the power line just ahead of the power unit. Use wire capable of supporting a 30-amp circuit
- Warning: – the wiring must comply with local code. Have a certified electrician make the electrical hook-up to the power unit. Protect each circuit with time delay fuse or circuit breaker; 208v-230v single phase 60 Hz 30 amp.
- STEP 26.** Do not place any vehicle on the lift at this time. Cycle the lift up and down several times to insure latches click together and all air is removed from the system. To lower the lift, both latch releases must be manually released. Latches will automatically reset once the lift ascends approximately 17" (431.8mm) from base. If latches click out of sync, tighten the cable on the one that clicks first.
- STEP 27.** With lift fully lowered, recheck power unit fluid level. Fill as required.

LIFT LOCKOUT/TAGOUT PROCEDURE

Purpose

This procedure establishes the minimum requirements for the lockout of energy that could cause injury to personnel by the operation of lifts in need of repair or being serviced. All employees shall comply with this procedure.

Responsibility

The responsibility for assuring that this procedure is followed is binding upon all employees and service personnel from outside service companies (i.e., Authorized Installers, contactors, etc.). All employees shall be instructed in the safety significance of the lockout procedure by the facility owner/manager. Each new or transferred employee along with visiting outside service personnel shall be instructed by the owner/manager (or assigned designee) in the purpose and use of the lockout procedure.

Preparation

Employees authorized to perform lockout shall ensure that the appropriate energy isolating device (i.e., circuit breaker, fuse, disconnect, etc.) is identified for the lift being locked out. Other such devices for other equipment may be located in close proximity of the appropriate energy isolating device. If the identity of the device is in question, see the shop supervisor for resolution. Assure that proper authorization is received prior to performing the lockout procedure.

Sequence of Lockout Procedure

- 1) Notify all affected employees that a lockout is being performed and the reason for it.
- 2) Unload the subject lift. Shut it down and assure the disconnect switch is "OFF" if one is provided on the lift.
- 3) The authorized lockout person operates the main energy isolation device removing power to the subject lift.
 - a. If this is a lockable device, the authorized lockout person places the assigned padlock on the device to prevent its unintentional reactivation. An appropriate tag is applied stating the person's name, at least 3" x 6" (76 x 152mm) in size, an easily noticeably color, and states not to operate device or remove tag.
 - b. If this device is a non-lockable circuit breaker or fuse, replace with a "dummy" device and tag it appropriately as mentioned above.
- 4) Attempt to operate lift to assure the lockout is working. Be sure to return any switches to the "OFF" position.
- 5) The equipment is now locked out and ready for the required maintenance or service.

Restoring Equipment to Service

- 1) Assure the work on the lift is complete and the area is clear of tools, vehicles, and personnel.
- 2) At this point, the authorized person can remove the lock (or dummy circuit breaker or fuse) and tag and activate the energy isolating device so that the lift may again be placed into operation.

Rules for Using Lockout Procedure

Use the Lockout Procedure whenever the lift is being repaired or serviced, waiting for repair when current operation could cause possible injury to personnel, or for any other situation when unintentional operation could injure personnel. No attempt shall be made to operate the lift when the energy isolating device is locked out.

Operating Conditions

Lift is not intended for outdoor use and has an operating ambient temperature range of 41°-104°F (5°-40°C).

SAFETY AND OPERATING INSTRUCTIONS

Only authorized personnel are to operate lift

Read operating and safety procedures manual completely before operating lift.

- Properly maintain and inspect lift in accordance to owner's manual.
- Do not operate a lift that is damaged or in need of repair.
- Allow only authorized personnel in the lift bay.
- Stay clear of Lift when raising or lowering (NO RIDERS)
- Keep hands and feet away from pinch points at all times.
- Never override the Lifts operating and safety controls.
- If a vehicle is suspected of falling, clear area immediately.
- Do not rock vehicle while positioned on lift.
- Always use safety jack stands when removing or installing heavy components.

Vehicle Loading

- Position vehicle for proper weight distribution (center of gravity should be midway between adapters).
- Swing arms under vehicle to allow adapters to contact at the manufacturer's recommended pick up points.
- Use caution before lifting pickup trucks, SUV's and other framed vehicles. The individual axle weight capacity should not exceed 1/2 of lift capacity.
- Make sure vehicle is neither front nor rear heavy.
- Make sure the lifting pads are in a proper and safe position to support the vehicle.
(Ref: Lifting Points Guide and decal on Main side column for typical arm positioning)

Raising Lift

- Push Up switch to raise lift (make sure arm restraints engage or stop and slightly move arm to allow gear to mesh) until tires clear floor.
- Stop and check for secure contact on adapters and vehicle weight distribution. If secure raise to desired height.
- ALWAYS lower the lift into the nearest lock position by pressing the lower lever to relieve the hydraulic pressure and let the latch set right in a lock position.
- Never work under a lift that is not in the locked position.

Lowering Lift

- Clear all obstacles from under lift and vehicle and ensure only the lift operator is in the lift area.
- Stay clear of lift and raise the lift off the safety locks.
- Pull safety latch releases and press the lower lever to begin descent.
- Unload lift by first completely lowering lift, then swinging arms to drive-thru position before moving vehicle.

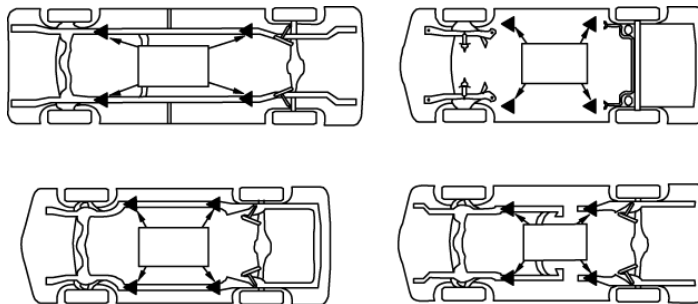

Lift Points Note:

Refer to the manufacturer's specific vehicle lifting points. Some vehicles display these points on a label inside the right front door lockface or are identified by triangle shape marks on the vehicle's undercarriage, reference SAE J2184.

SAFETY PROCEDURES

- Never allow unauthorized persons to operate lift. Thoroughly train new employees in the use and care of lift.
- Caution - the power unit operates at high pressure.
- Remove passengers before raising vehicle.
- Prohibit unauthorized persons from being in shop area while lift is in use.
- Total lift capacity is 9,000 lbs. (4 tonne) @ 2,250 lbs (1.02 tonne) per lifting pad. Do not exceed maximum weight capacity of lift.
- Prior to lifting vehicle, walk around the lift and check for any objects that might interfere with the operation of lift and safety latches; tools, air hoses, shop equipment.
- When approaching the lift with a vehicle, make sure to center the vehicle between the columns so that the tires will clear the swing arms easily. Slowly drive the vehicle between the columns. It is recommended to have someone outside the vehicle guide the driver.
- Always lift vehicle using all four pads.
- Never use lift to raise one end or side of vehicle.
- Always raise vehicle about 3" (76mm) and check stability by rocking vehicle.
- Prior to lowering vehicle, walk around the lift and check for any objects that might interfere with the operation of lift and safety latches; tools, air hoses, shop equipment.
- Always lower lift to the lock position before going under vehicle.
Never allow anyone to go under the lift when raising or lowering.

PREVENTIVE MAINTENANCE SCHEDULE

The periodic Preventive Maintenance Schedule given is the suggested minimum requirements and minimum intervals; accumulated hours or monthly period, whichever comes sooner. Periodic maintenance is to be performed on a daily, weekly, and yearly basis as given in the following paragraphs.

WARNING!!

Occupational Safety and Health Administration (OSHA) and the American National Standards Institute (ANSI) requires users to inspect lifting equipment at the start of every shift. These and other periodic inspections are the responsibility of the user.

Failure to perform the daily pre-operational check can result in expensive property damage, lost production time, serious personal injury, and even death. The safety latch system must be checked and working properly before the lift is put to use.

Failure to heed this warning can result in death or serious injury, or damage to equipment. If you hear a noise not associated with normal lift operation, or, if there is any indications of impending lift failure - CEASE OPERATION IMMEDIATELY! - Inspect, correct and/or replace parts as required.

Daily Pre-Operation Check (8-Hours)

1. Check safety lock audibly and visually while in operation
2. Check safety latches for free movement and full engagement with rack.
3. Check hydraulic connections, and hoses for leakage.
4. Check chain connections - bends, cracks-and loose links.
5. Check cable connections- bends, cracks-and looseness.
6. Check for frayed cables in both raised and lowered position.
7. Check snap rings at all rollers and sheaves.
8. Check bolts, nuts, and screws and tighten if needed.
9. Check wiring & switches for damage.
10. Keep base plate free of dirt, grease or any other corrosive substances.
11. Check floor for stress cracks near anchor bolts.
12. Check swing arm restraints.

Weekly Maintenance (every 40-Hours)

1. Check anchor bolts torque to 50 ft-lbs (67.8nm) for the ¾ in. (19.05mm) anchor bolts. Do not use an impact wrench to tighten anchor bolts.
2. Check floor for stress cracks near anchor bolts.
3. Check hydraulic oil level.
4. Check and tighten bolts, nuts, and screws.
5. Check cylinder pulley assembly for free movement or excessive wear on cylinder yoke or pulley pin.
6. Check cable pulley for free movement and excessive wear.

Yearly Maintenance

1. Lubricate chains
2. Grease rub blocks and column surface contacting rub blocks

3. Change the hydraulic fluid - good maintenance procedure makes it mandatory to keep hydraulic fluid clean. No hard fast rules can be established; - operating temperature, type of service, contamination levels, filtration, and chemical composition of fluid should be considered. If operating in dusty environment shorter interval may be required.

Special Maintenance Tasks

NOTE: The following items should only be performed by a trained maintenance expert:

- Replacement of hydraulic hoses.
- Replacement of chains and rollers.
- Replacement of cables and sheaves.
- Replacement or rebuilding air and hydraulic cylinders as required.
- Replacement or rebuilding pumps / motors as required.
- Checking of hydraulic cylinder rod and rod end (threads) for deformation or damage.

CAUTION!!

Relocating or changing components may cause problems. Each component in the system must be compatible; an undersized or restricted line will cause a drop in pressure. All valve, pump, and hose connections should be sealed and/or capped until just prior to use. Air hoses can be used to clean fittings and other components. However, the air supply must be filtered and dry to prevent contamination. Most important is cleanliness; Contamination is the most frequent cause of malfunction or failure of hydraulic equipment

TROUBLESHOOTING

The common problems that may be encountered and their probable causes are covered in the following paragraphs:

PROBLEM	SOLUTION
Motor Does Not Operate	<p>Failure of the motor to operate is normally caused by one of the following:</p> <ol style="list-style-type: none"> 1. Breaker or fuse blown. 2. Faulty wiring connections; call electrician. 3. Defective up button; call electrician for service.
Motor Functions but Lift Will Not Rise	<p>If the motor is functioning, but the lift will not rise do the following in the order given:</p> <ol style="list-style-type: none"> 1. A piece of trash is under check valve. Push handle down and push the up button at the same time. Hold for 10-15 seconds. This should flush the system. 2. Check the clearance between the plunger valve of the lowering handle. There should be 1/16" clearance. 3. Remove the check valve cover and clean ball and seat. <p>WARNING!!</p> <p>Failure to properly relieve pressure in the following step can cause injury to personnel. This lift uses ISO Grade 32 or other good grade non-detergent hydraulic oil at a high hydraulic pressure. Be familiar with its toxicological properties, precautionary measures to take, and first aid measures as stated in the Safety Summary before performing any maintenance with the hydraulic system.</p> <ol style="list-style-type: none"> 4. Oil level too low. Oil level should be just under the vent cap port when the lift is down. Relieve all hydraulic pressure and add oil as required.
Oil Blows out Breather of Power Unit	<p>If oil blows out of the breather of the power unit, take the following actions:</p> <ol style="list-style-type: none"> 1. Oil reservoir overfilled. Relieve all pressure and siphon out hydraulic fluid until at a proper level 2. Lift lowered too quickly while under a heavy load. Lower the lift slowly under heavy loads.
Motor Hums and Will Not Run	<p>If the motor hums but fails to run, take the following actions:</p> <ol style="list-style-type: none"> 1. Lift overloaded. Remove excessive weight from lift <p>WARNING!!</p> <p>The voltages used in the lift can cause death or injury to personnel. In the following steps, make sure that a qualified electrician is used to perform maintenance</p> <ol style="list-style-type: none"> 2. Faulty wiring Call electrician 3. Bad capacitor Call electrician 4. Low voltage Call electrician
Lift Jerks Going Up and Down	<ol style="list-style-type: none"> 1. If the lift jerks while going up and down, it is usually a sign of air in the hydraulic system. Raise lift all the way to top and return to floor. Repeat 4-6 times. Do not let this overheat power unit.
Oil Leaks	<p>Oil leak causes at the power unit and cylinders are normally caused by the following:</p> <ol style="list-style-type: none"> 1. Power unit: if the power unit leaks hydraulic oil around the tank-mounting flange check the oil level in the tank. The level should be two inches below the flange of the tank. A screwdriver can be used as a "dipstick". 2. Cylinder - Piston Rod: the rod seal of the cylinder is out. Rebuild or replace the cylinder. 3. Cylinder - Vent: the piston seal of the cylinder is out. Rebuild or replace the cylinder.
Lift makes excessive noise / vibrates	<p>Excessive noise from the lift is normally caused by the following:</p> <ol style="list-style-type: none"> 1. Cross beam ends are rubbing the columns. Readjustment needed. 2. Cylinder too tight, load lift half capacity and cycle up and down a few times to break in. Lift cylinder should quiet down with use. If not contact your Direct Lift Distributor to purchase an Oil Additive. 3. May have excessive wear on cable sheaves or shafts. Replace them.

ILLUSTRATED PARTS BREAKDOWN

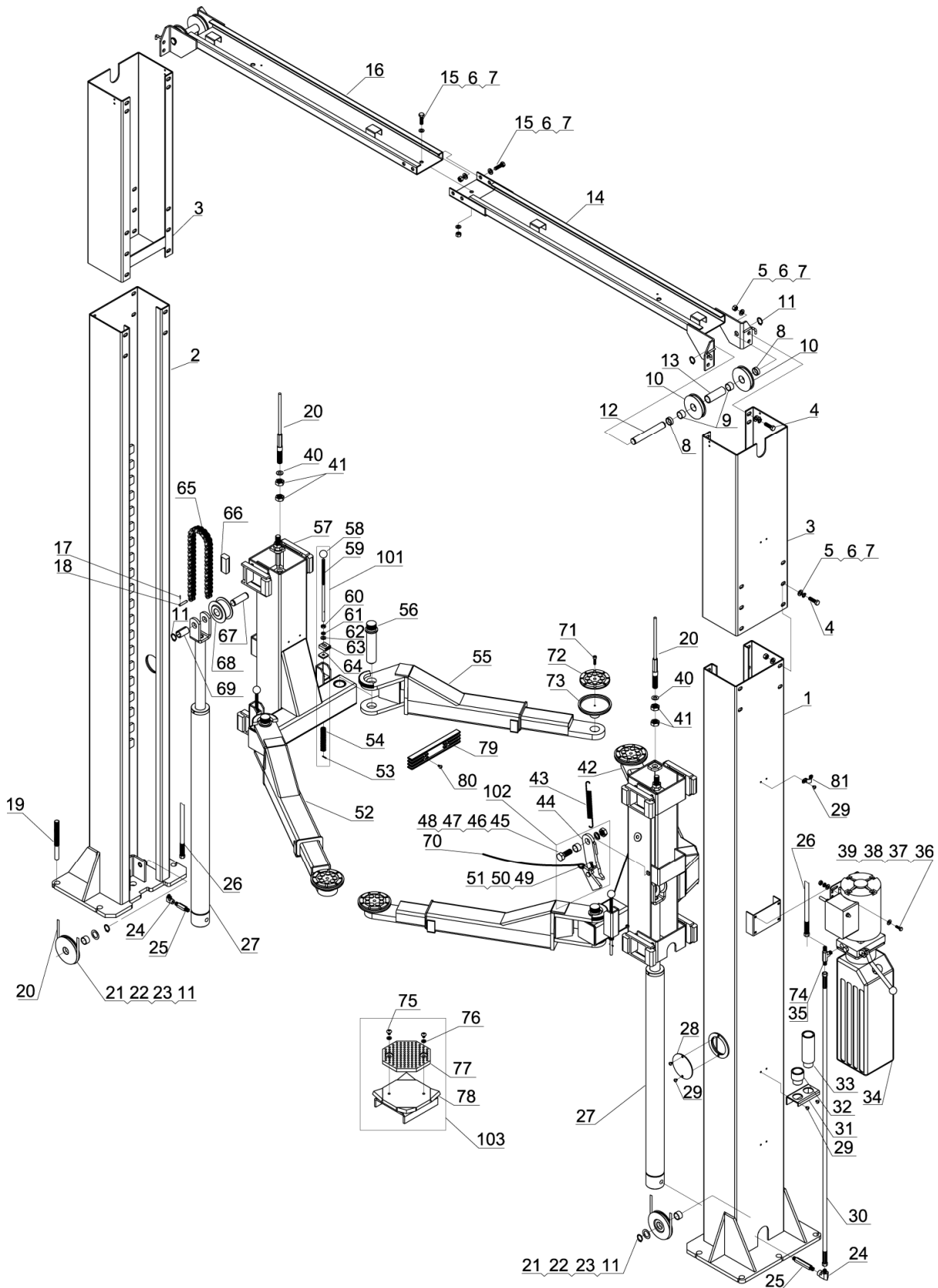

PARTS LIST OF OH LIFT

ITEM	DRAWING	DESCRIPTION	QTY
1	QL4W-2R1-00	RIGHT COLUMN WELDED GROUP	1
2	QL4W-2L1-00	LEFT COLUMN WELDED GROUP	1
3	QL4W-100-00	LONG COLUMN GROUP	1
4	GB5782-86	HEXAGONAL HEAD BOLT M12X40	24
5	GB93-87	LOCK WASHER 12	24
6	GB97.1-85	FLAT WASHER 12	34
7	GB6170-86	HEXAGON NUTS M12	29
8	QL4L-400-04	SHORT SLEEVE	4
9	QL40-700-02	THICK CABLE WHEEL BUSHING	4
10	QL4L-400-02 4"	THICK CABLE WHEEL	4
11	GB894.1-86	AXIAL ELASTIC RINGS 25	10
12	QL4L-400-01	PULLEY SHAFT	2
13	QL4L-400-03	LONG BUSHING	2
14	QL4L-4R0-00	RIGHT BEAM WELDING GROUP	1
15	GB5782-86	HEXAGONAL HEAD BOLT M12X25	5
16	QL4L-4L0-00	LEFT BEAM WELDING GROUP	1
17	GB91-86	SPLIT PIN 2X20	8
18	QL40-000-12	CHAIN PIN	4
19	QL4W-000-03	SWELLING BOLT GROUP	10
20	QL4L-600-00	WIRE ROPE PARTS	2
21	QL40-200-03	CABLE WHEEL	2
22	QL40-200-04	CABLE WHEEL WASHER	2
23	QL40-200-05	SLEEVE BUSHING	2
24	QL40-000-09	INTERNAL AND EXTERNAL CONNECTIONS	2
25	QL40-000-B10	ANTI-RIOT BARREL CONNECTOR	2
26	QL40-100-00	CYLINDER PARTS	2
27	QL4W-000-02	OIL PIPE (JOINT-TANK)	1
28	QL40-200-01	WINDOW PANEL	2
29	GB818-85	CROSS RECESSED PAN HEAD SCREW M6X8	20
30	QL40-000-08	OIL PIPE (VALVE-TANK)	1
31	QL4L-000-18	FRID	2

32	QL40-000-04	SHORT JOINTS	4
33	QL40-000-05	LONG JOINT	4
34	QL4L-000-21	HYDRAULIC POWER UNITS	1
35	QL4W-000-01	TEE CONNECTOR	1
36	GB5782-86	HEXAGONAL HEAD BOLT M8X25	4
37	GB97.1-85	FLAT WASHER 8	8
38	GB93-87	LOCK WASHER 8	4
39	GB6170-86	HEXAGON NUTS M8	4
40	GB97.1-85	FLAT WASHER	20
41	GB6170-86	HEXAGON NUTS M20	8
42	QL4W-500-R0	RIGHT BEND ARM OF WELDING GROUP	1
43	QL40-500-02	EXTENSION SPRING	2
44	QL40-521-00	INSURANCE BOLCK WELDING GROUP	2
45	GB5783-86	HEXAGONAL HEAD BOLT M20X50	2
46	QL40-500-03	SLEEVE BUSHING	2
47	GB93-87	LOCK WASHER 20	2
48	GB6170-86	HEXAGON NUTS M20	2
49	GB818-85	CROSS RECESSED PAN HEAD SCREW M6X35	2
50	GB97.1-85	FLAT WASHER 6	2
51	QL40-520-01	COMPRESSION SPRING	2
52	QL4W-400-00	STRAIGHT ARM OF WELDING GROUP	2
53	GB879-86	ELASTIC CYLINDRICAL PIN	4
54	QL40-530-02	COMPRESSION SPRING	4
55	QL4W-500-L0	LEFT BEND ARM OF WELDING GROUP	1
56	QL40-800-00	BOLT WELDING GROUP	4
57	QL4W-310-00	SLIPWAY WELDING GROUP	2
58	QL40-000-15	HANDLE THE BALL M10	4
59	QL40-530-01	DRAFT BAR	4
60	GB6170-86	HEXAGON NUTS M10	4
61	GB93-87	LOCK WASHER 10	4
62	GB97.1-85	FLAT WASHER 10	8
63	QL40-530-04	RACK	4
64	QL40-530-03	GEAR GASKET	4

65	QL40-200-02	DRAY CHAIN	2
66	QL40-500-01	SLIDE BLOCK	16
67	QL40-100-03	ROLLED AXLE	2
68	QL40-100-02	CONTACT ROLLER	2
69	QL40-100-04	BEARING HPB	2
70	QL40-500-04	WIREROPE	2
71	GB70-85	HEXALOBULAR SOCKET CHEESE HEAD SCREWS M6X20	4
72	QL40-000-03	PALLET PAD	4
73	QL40-000-02	PALLET	4
74	O-RING		1
75	GB819-85	CROSS RECESSED COUNTERSUNK HEAD SCREW M6X12	4
76	GB97.1-85	FLAT WASHER 6	4
77	QL4L-X20-01	BRACKET PAD	2
78	QL4L-X21-00	BRACKET WELDED GROUP	4
79	QL4W-000-04	DOOR SHIELD	2
80	GB818-85	CROSS RECESSED COUNTERSUNK HEAD SCREW M6X20	4
80	QL4L-000-05	STAPLE BOLT	6
101	QL4L-320-00	RACK - ROD COMPONENTS	4
102	QL40-520-00	INSURANCE STOPPER BLOCKS	2
103	QL4L-X20-00	BRACKET PARTS	2

WARRANTY

Our Contact Details

Tufflift Imports Pty Ltd T/As Tufflift Hoists Australia

T: 03 9470 7200

E: enquiries@tufflift.com.au

Warranty

1. **Our goods come with guarantees that cannot be excluded under the Australian Consumer Law. You are entitled to a replacement or refund for a major failure and for compensation for any other reasonably foreseeable loss or damage. You are also entitled to have the goods repaired or replaced if the goods fail to be of acceptable quality and the failure does not amount to a major failure.**

2. The benefits under this warranty are in addition to other rights and remedies under a law in relation to the goods.

3. We warrant that these goods are free from defects in workmanship and materials for a period of 12 months from the date of purchase where the goods have been paid for in full and:

3.1. have not been installed; or

3.2. have been installed by a suitably qualified professional installer of goods of this type in accordance with the Installation, Operation, Maintenance and Instruction Manual which is supplied with the goods at the time of purchase.

4. Subject to the conditions of warranty set out below, if the goods fail to operate for any reason within the applicable warranty period, we will repair or replace the goods free of charge.

5. Apart from any consumer guarantees under the Australian Consumer Law all other warranties, express or implied, and whether arising by virtue of statute or otherwise, are hereby excluded.

Conditions of Warranty

1. To make a warranty claim:

1.1. the goods, a copy of this warranty, proof of purchase and an explanation of the defect must be sent to us at the address specified in this warranty; and

1.2. the goods must not have had their serial number (if any) removed, defaced or changed, their casing open, their power cord altered, nor have been tampered with in any other way.

2. Freight costs and travel expenses associated with compliance with this warranty and the repair or replacement of the goods under warranty are for your account, save for where we conduct an onsite repair of the goods at a location that is within 30 kilometres of one of our authorised service agents.

3. This warranty will be invalidated and will not apply in relation to loss, damage or deterioration to a goods which is caused by any of the following:

3.1. failure to handle, store, install, service or maintain the goods in accordance with the Installation, Operation, Maintenance and Instruction Manual which is supplied with the goods at the time of purchase;

3.2. impact or contact with objects or substances brought into proximity with the goods as a result of direct or indirect human intervention;

3.3. the collapse or movement of the structure on which the goods are mounted or the removal or weakening of the foundations upon which the goods are mounted;

3.4. deliberate or careless acts or omissions on your part or on the part of your employees, agents, subcontractors or any other party, excluding ourselves and our distributors;

3.5. unauthorized modifications or alterations of any part of the goods;

3.6. any event beyond our control, including, but not limited to earthquake, fire, flood, lightning, strong wind, heavy hail, or the build-up of snow or other natural substances;

3.7. use of the goods in an outdoor environment;

3.8. exposure to corrosive or other adverse environmental elements;

3.9. cosmetic damage, damage to electrical cords, dents, electrical overload, surge, spikes and or lost / missing parts.

3.10. normal wear and tear;

3.11. loading in excess of the weight capacity or operating limitations displayed on the goods specifications;

3.12. use of the goods for a purpose other than those for which it was designed;

3.13. use of the incorrect voltage on the goods; or

3.14. shipment of the goods.

4. If the goods or parts are replaced under warranty, this warranty will apply to the replacement parts for the duration of the unexpired portion of the original warranty.

5. No amendment to this warranty will be valid or binding unless recorded in writing and signed by our authorised officer.

6. Subject to the Australian Consumer Law and any other applicable state or federal law:

6.1. we expressly disclaim any responsibility for any other warranty issued by any other party in respect to any component or goods purchased from us or the specification, design, manufacture or installation thereof. All claims under warranties issued by third parties must be directed to those third parties;

6.2. this warranty is given for the benefit of the first owner only and is not transferable. Any claims by parties other than the original purchaser will not be recognised.

Warranty Information Section - Complete this section for your records

Goods Type: _____ Date of purchase: _____ Invoice Number: _____

Model Number: _____ Serial Number: _____

Name on Invoice: _____

