

3000KG
Capacity

110mm
Min Height

Quite Running

Curved Start-Up Supporting Plates make quite ground touching when lift lowered completely.

Double Safety

Hydraulic and Mechanical



MAIN FEATURES

- 3000KG lifting capacity
- Surface or recessed mount
- 110mm minimum height
- Four cylinder design
- Pneumatic safety locking system
- Drive-on ramps lock into position as platform extensions.
- Steady raising and lowering, no noise when lowered to ground touching.
- Durable cylinders with anti-surge valves
- 24V safe control system.
- Height limit switch
- Powder coated finish
- Self-lubricated bushing and bearing.
- Aluminum motor with fan on top to avoid overheating caused by long time working.
- It has been proofed by dynamic test with 115% of rated capacity and static test with 150% capacity.
- Installation and Operation Manual and Labels in Chinese, English, Spanish, German, French, Russian, Swedish (Other Languages Available Upon Request)

TECHNICAL DATA

MODEL NO.	EE-6501
Lifting capacity	3,000Kg
Max lifting height	1,850mm
Min height	110mm
Lifting time	50S
Capacity of motor	2.2KW
Air supply	6~8Kg/cm ²
Platform width	650mm
Weight	900Kg
Electricity supply	220/230/240/380/400/415V 3PH 220V 1 PH

Note: Electrical leveling is also available

FULL RISE SCISSOR LIFT

EE-6501

OVERALL DIMENSION

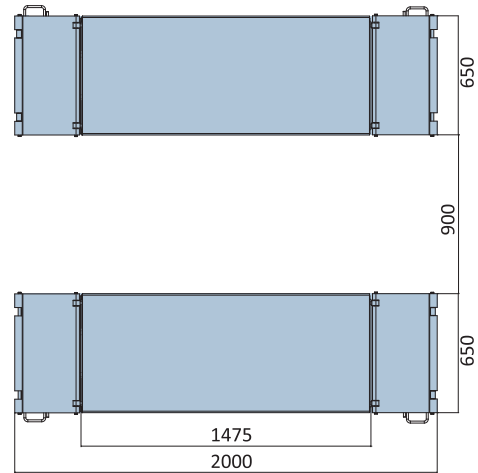
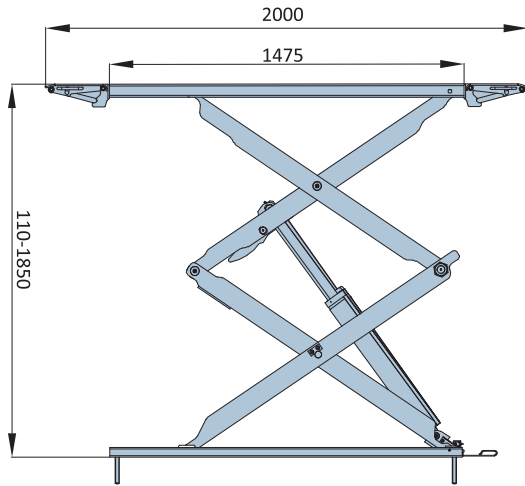

DETAIL DISPLAY



Mechanical Safety Lock



Extendible Platform



Low Voltage Control Unit



High Quality Ball Valve

