



SPECIFICATIONS

Model	Lifting Capacity	Lifting Height	Lifting Time	Overall Height	Overall Width	Drive Thru Clearance	Width Between Columns	Minimum Pad Height	Motor
PK3.70H	3700Kg	1815 - 2085mm	52 Seconds	3621 / 3821mm	3428mm	2528mm	2850mm	115mm	2.0 / 3.0 HP

FEATURES

- 3700kg Capacity
- Clear floor
- Dual hydraulic direct-drive cylinders
- Single point safety release with dual safety design
- Overhead safety shut off device
- Supersymmetric arm design
- Automatic arm locks
- Combination screw pads

- Stackable adapters and hydraulic oil included
- Installation service available subject to location
- 2 Year hydraulic, electrical and mechanical warranty
- 5 Year structural warranty
- Australian Standards Certification
- Worksafe Design Registration

Tufflift Hoists Australia

Head Office 2 Dairy Drive, Coburg North, VIC 3058 Phone +61 3 9470 7200
 Fax +61 3 9470 7209 Email enquiries@Tufflift.com.au Freecall 1800 Tufflift (88 33 54)



HOISTS FOR EVERY SPACE

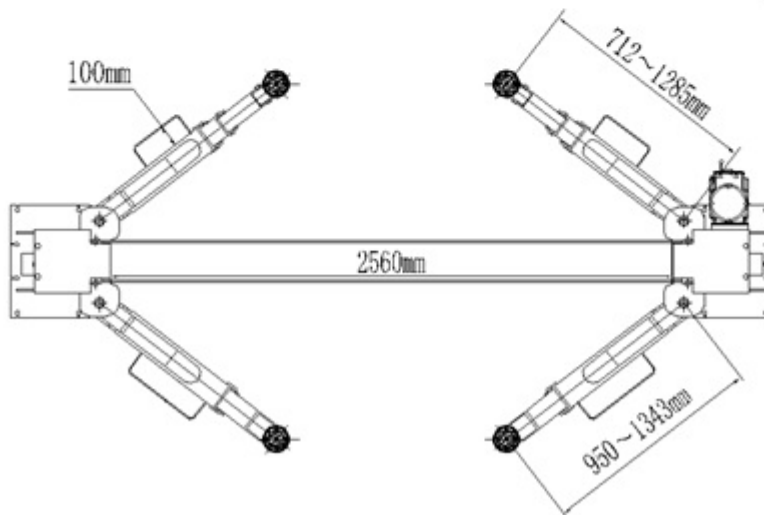
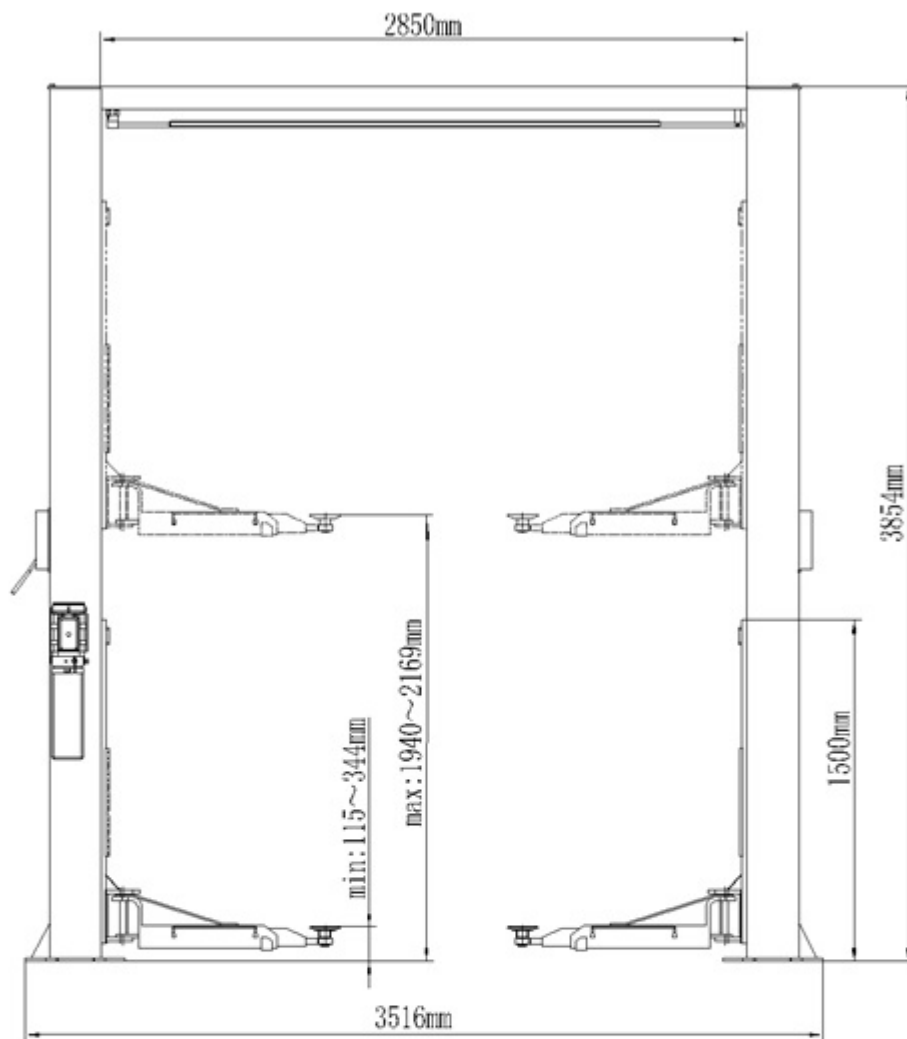

Tufflift Hoists Australia

Head Office 2 Dairy Drive, Coburg North, VIC 3058 Phone +61 3 9470 7200
Fax +61 3 9470 7209 Email enquiries@Tufflift.com.au Freecall 1800 Tufflift (88 33 54)



HOISTS FOR EVERY SPACE