

SPECIFICATIONS

Model	Lifting Capacity	Lifting Height	Width Between Columns	Overall Height	Overall Width	Drive Thru Clearance	Lifting Time	Minimum Height	Motor
EAE-62C	4200Kg	1900mm	2840mm	2825mm	3580mm	2500mm	50 Sec	90mm	2.0/ 3.0HP

FEATURES

- 4200kg Capacity
- Hydraulic oil included
- Heavy duty lift pads
- 1900mm lifting height
- Screw-up lifting pads
- Aluminum motor to avoid over heating

- Available in single or three phase
- Installation service available subject to location
- 2 Years hydraulic, electrical and mechanical warranty
- 5 Year structural warranty
- Australian Standards Certification
- Worksafe Design Registration

Tufflift Hoists Australia

Head Office 46 Saintly Drive, Truganina, VIC 3029 Phone +61 3 8375 3600
 Fax +61 3 8353 2525 Email enquiries@Tufflift.com.au Freecall 1800 Tufflift (88 33 54)



HOISTS FOR EVERY SPACE

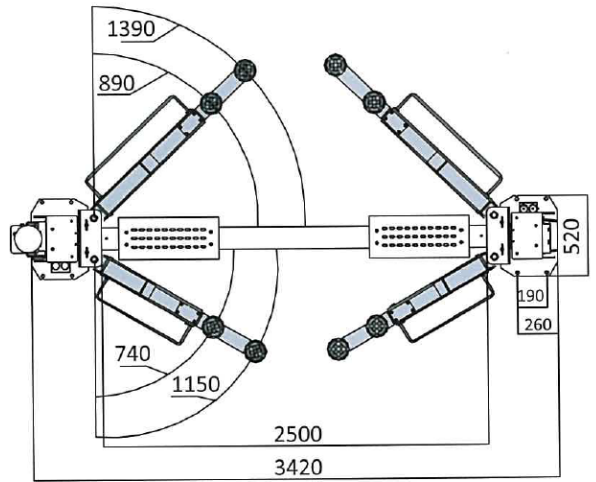
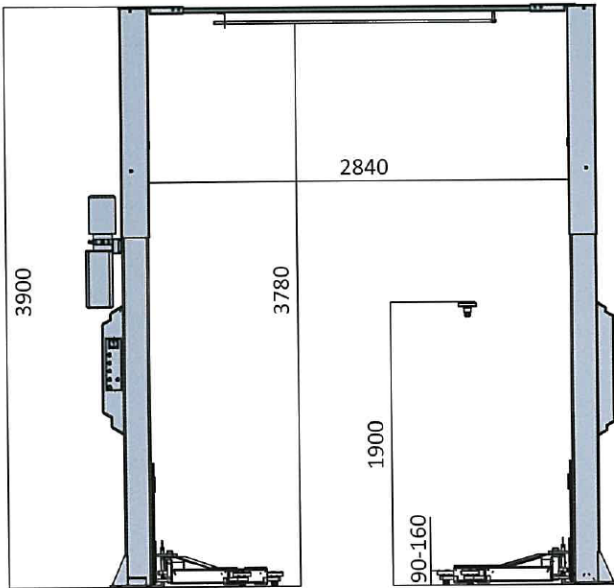

DETAIL DISPLAY



Lock system

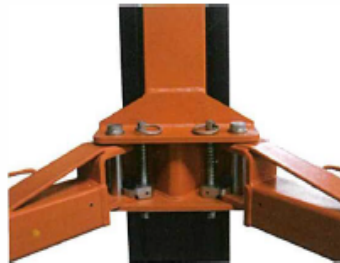

Strong Carriage and Arm Structure



4T130mm Casting Height Adapter



Chain protection



24 Control Box



Round Screw-up Lifting Pad

Tufflift Hoists Australia

Head Office 46 Saintly Drive, Truganina, VIC 3029 Phone +61 3 8375 3600

Fax +61 3 8353 2525 Email enquiries@Tufflift.com.au Freecall 1800 Tufflift (88 33 54)



HOISTS FOR EVERY SPACE