



89mm ADAPTER



127mm ADAPTER

SPECIFICATIONS									
Model	Lifting Capacity	Maximum Rise	Overall Height	Overhead Switch Height	Overall Width	Front/Rear Reach Min/Max	Lifting Pad Height	Width Between Columns	Motor
TLV5.50H	5.5 Ton	1848 mm	4216 mm	4067mm	3556-3708 mm	891/1372mm	121 mm	2918/3070 mm	3 Phase/ 415V

## FEATURES

### 5.5 Ton Capacity

The TLV5.50H features low-profile, oversize pads with multiple extensions to raise different sized vehicles.

### 3 - Stage front and rear arms

Hydraulic cylinders in each column with full stroke and cylinder rod concealed inside carriage

### Overhead cable equalization

Single point lock release

Optional Height Extension Kit available

Durable powder-coated finish

Includes four adapter extensions at 89 mm and 127 mm

Includes hydraulic oil

Installation service available

12 Months hydraulic, electrical and mechanical warranty

5 Year structural warranty

Australian Standards Certification

Worksafe Design Registration

ALI USA certified

### Tufflift Hoists Australia

Head Office 46 Saintly Drive, Truganina, VIC 3029 Phone +61 3 8375 3600  
 Fax +61 3 8353 2525 Email sales@tufflift.com.au Freecall 1800 88 33 50



TLV5.50H

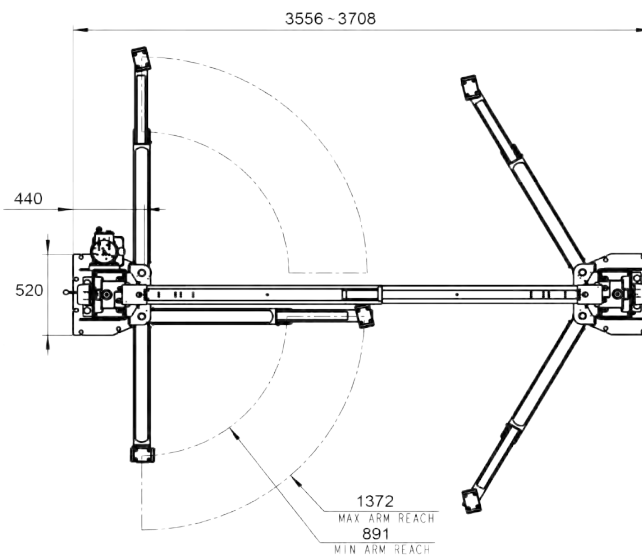
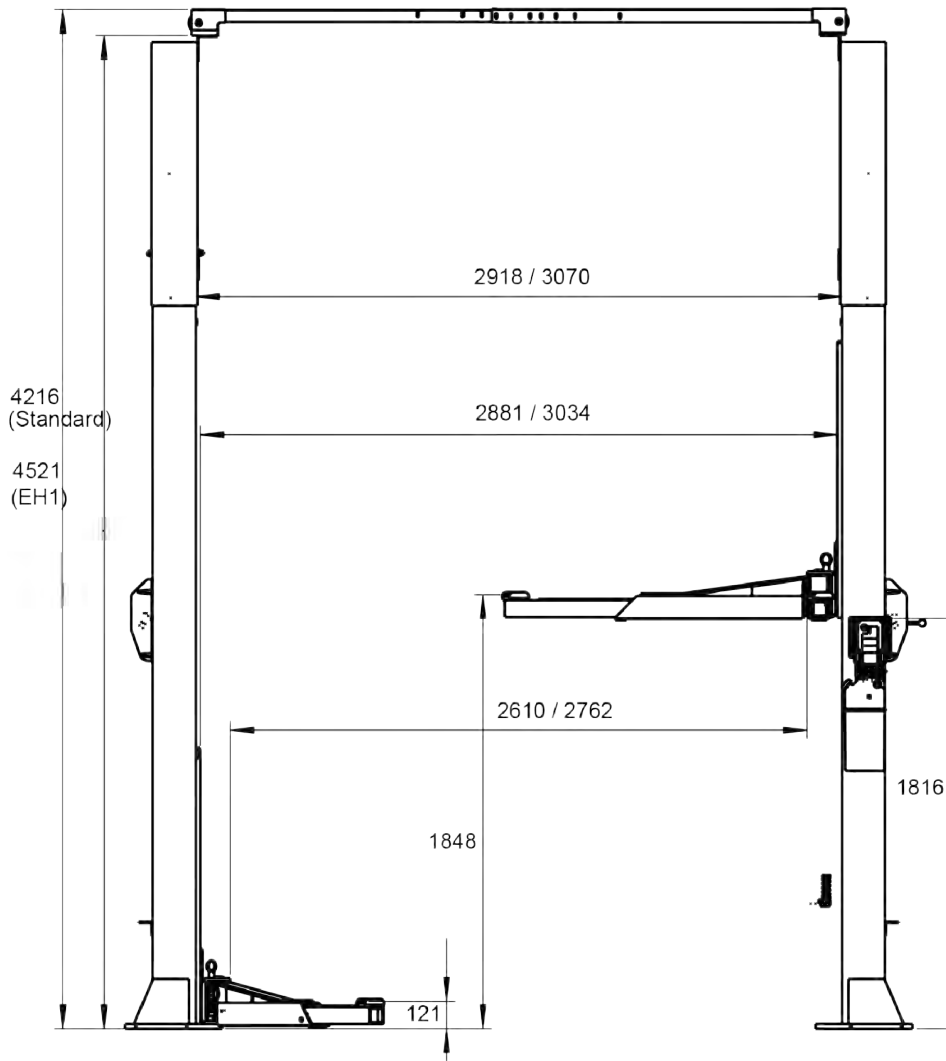

Tufflift Hoists Australia

Head Office 46 Saintly Drive, Truganina, VIC 3029 Phone +61 3 8375 3600  
 Fax +61 3 8353 2525 Email sales@tufflift.com.au Freecall 1800 88 33 50

