



EE-C10

MANUAL RELEASE TWO POST LIFT



Photo is for display purposes only, the EE-C10 has 4 x 2-piece arms.

4.5T
10000LBS.
Lifting Capacity

95MM
3 3/4"
Min. Height

1800MM
70 7/8"
Max. Lifting Height

EE-C10 MANUAL RELEASE TWO POST LIFT

Main Features

- 4500kg(10000LBS.) lifting capacity.
- 1900mm(74 3/4") Max. lifting height with standard SUV adapters. Single
- side release for mechanical safety locking unit.
- Cylinder straight top device, run more smoothly.
- Clear floor design for easy movement of maintenance equipment under the raised vehicle.
- Durable cylinders in each column carry with anti-surge valves.
- Screw-up lifting pads with clearance height less than 95mm(3 3/4").

Overall Dimension & Technical Data

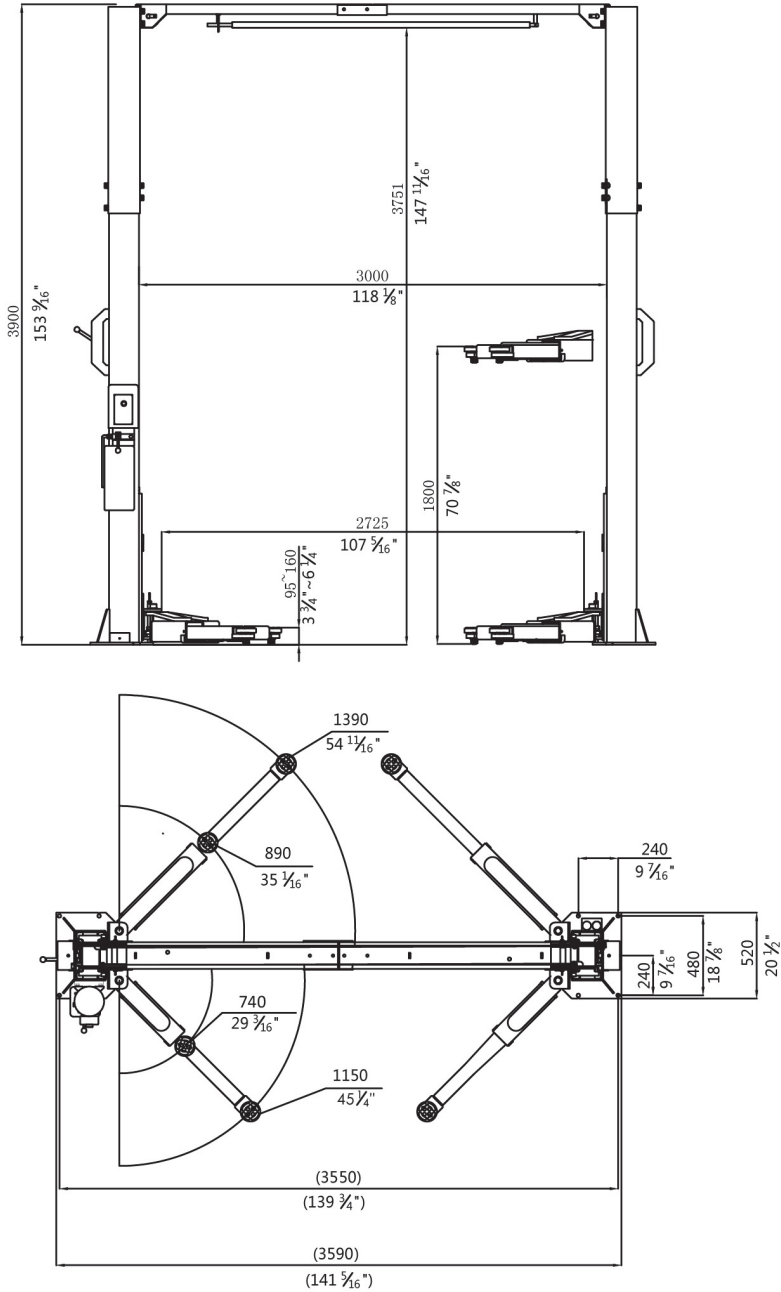

MODEL NO.	EE-C10
Lifting capacity	4500KG(10000LBS)
Column height	3900mm(153 9/16")
Max lifting height	1800mm(70 7/8")
Max lifting height with standard SUV adapters	1900mm(74 3/4")
Min height	95mm(3 3/4")
Lifting time	55S
Capacity of motor	2.2KW
Rated oil pressure	18Mpa
Drive through	2725mm(107 5/16")
Weight	644KG(1420LBS)
Electricity supply	According To Customer Needs

*Lifting height is measured with adjustable screw pads in highest position.
Machine shown with optional equipment. Actual product appearance may differ.