



# Quality hoists you can trust

Tufflift offers a complete range of car, truck and motorcycle hoists for every application. Our extensive range caters for both enthusiasts and professionals. If you need a 2 post for a workshop, a 4 post for storage at home or specialised equipment for commercial workshops and service centres, we have a hoist to suit every space and budget.

**View our complete range at [www.tufflift.com.au](http://www.tufflift.com.au)**

- 2 Post Clear Floor Automotive Hoists
- Motorcycle Lifts
- Auto Body Rotisserie
- 2 Post Base Plate Automotive Hoists
- General Garage Equipment
- 4 Post Automotive Hoists
- Each hoist is built to comply with the required Australian standards
- Worksafe design registered
- Structural, electrical and hydraulics warranties



**Freecall 1800 88 33 50**

**HEAD OFFICE / WAREHOUSE**  
46 Saintly Drive, Truganina VIC 3029

**NSW WAREHOUSE**  
Smithfield NSW 2164

**QLD WAREHOUSE**  
Richlands QLD 4077

**WA WAREHOUSE**  
Perth Airport WA 6105



HOISTS FOR EVERY SPACE

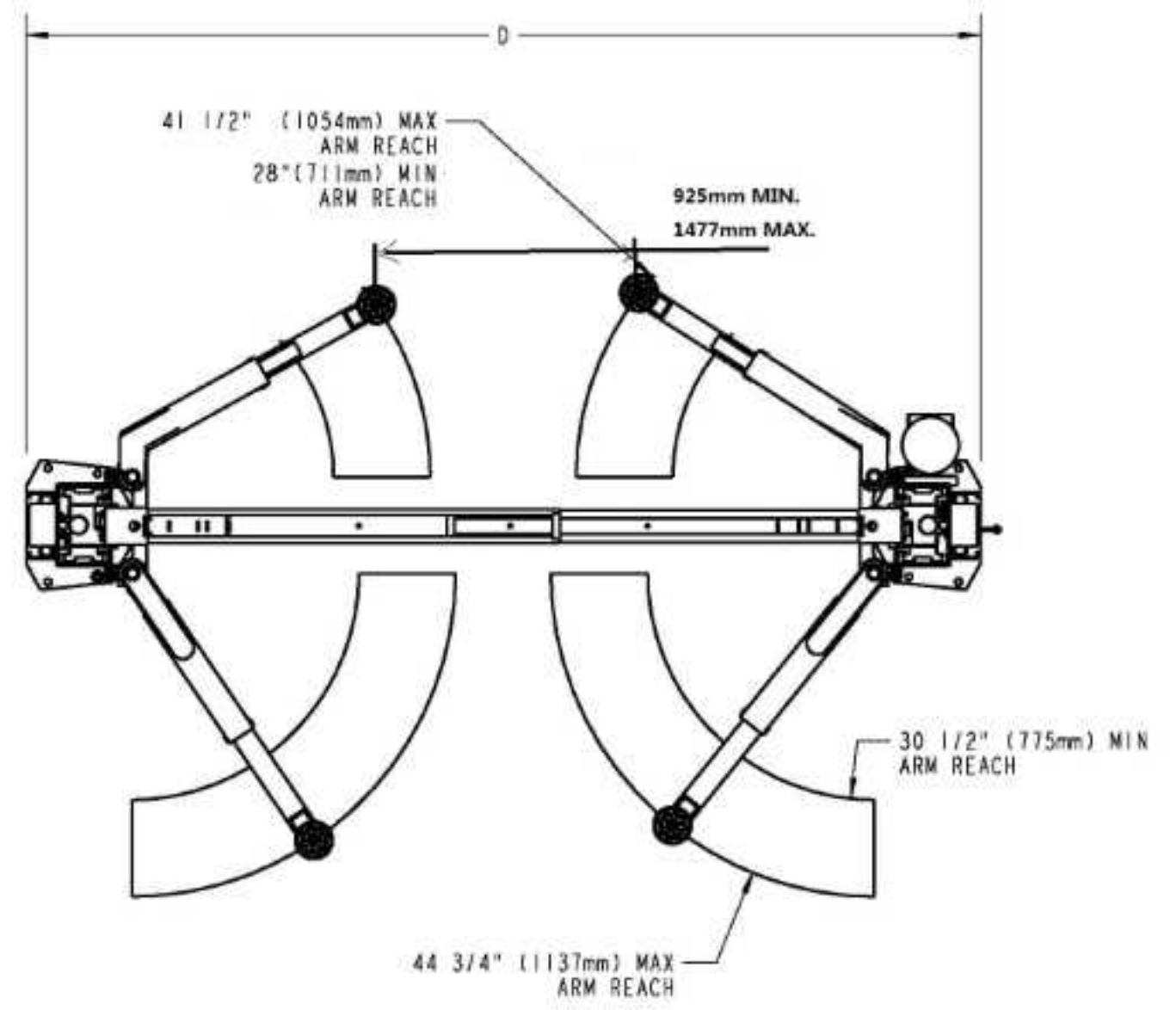
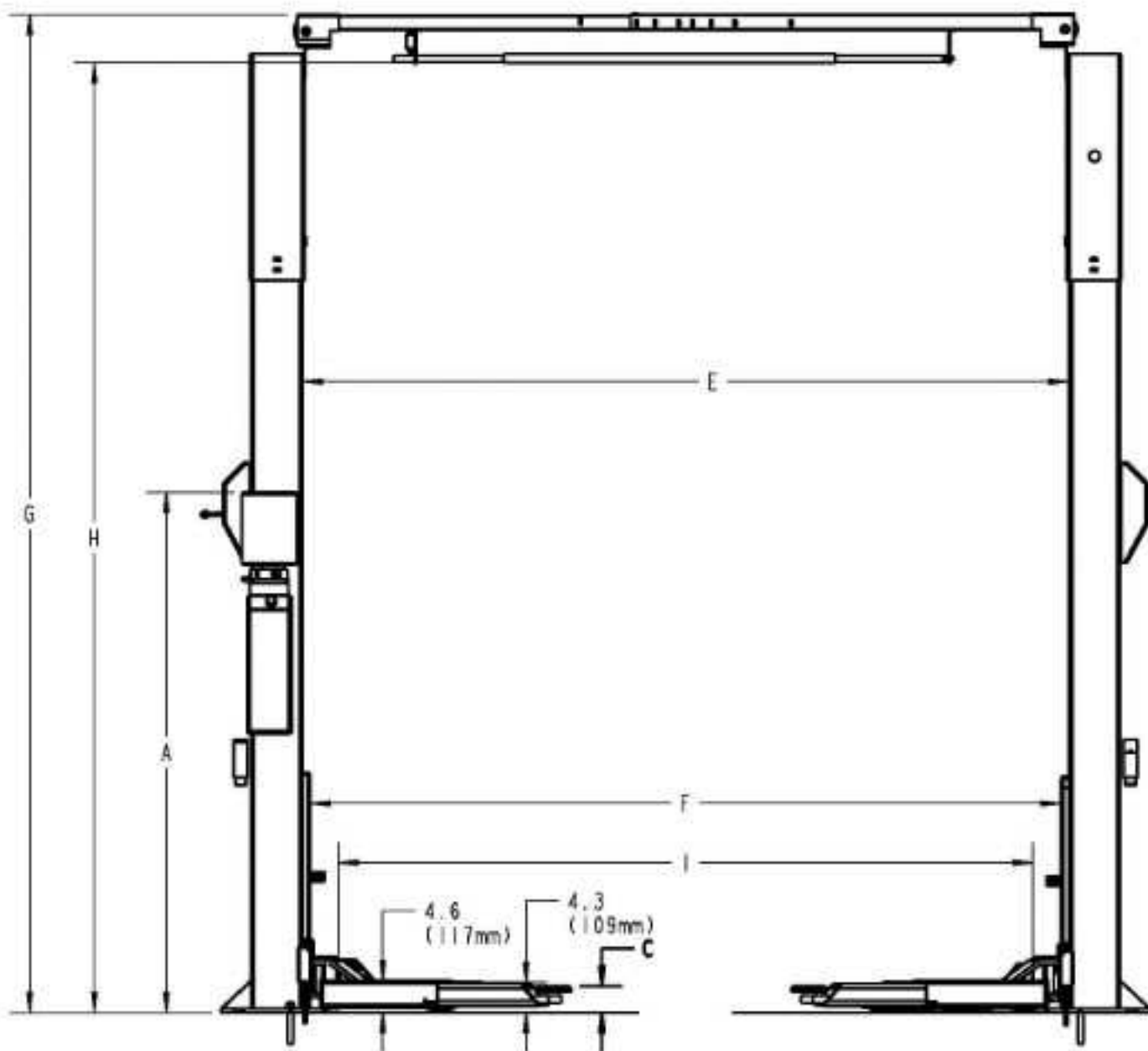

NOTES:  
 1.) ALL HEIGHT DIMENSIONS ARE WITHOUT LEVELING SHIMS.  
 2.) ANCHORING SYSTEM TESTED TO ANSI/ALI ALCTV: 2006

A	POWER UNIT HEIGHT	72-1/2" (1841.5mm)
B	LIFTING HEIGHT W/ 5" EXTENSION	76-5/8" (1946mm) W/ 68" (1727mm) STROKE
C	MIN. LIFT HEIGHT	3-5/8" (92mm)
	MIN. LIFT HEIGHT W/ 1 3/4" ADAPTER	5-3/8" (136.5mm)
	MIN. LIFT HEIGHT W/ 5" ADAPTER	8-5/8" (219mm)
D	OVERALL FLOOR WIDTH	131" (3327mm)
E	INSIDE COLUMNS	109" (2769mm)
F	WIDTH BETWEEN CARRIAGES	107" (2718mm)
G	HEIGHT OVERALL	142" (3607mm)
	MINIMUM CEILING HEIGHT	144" (3658mm)
H	FLOOR TO OVERHEAD SWITCH	137-5/8" (3496mm)
I	DRIVE THRU CLEARANCE	90-1/4" (2292mm)

LIFT CAPACITY	9,000 LBS. (4000kg)
LIFTING SPEED - RISE TIME (1Ø 60Hz)	APPROXIMATELY 51 SECONDS UNLOADED APPROXIMATELY 59 SECONDS AT RATED CAPACITY
MOTOR RATING OPTIONS	SINGLE PHASE 208-240 VOLTS 50-60Hz 18-23 AMPS THREE PHASE 208-230/460 VOLTS 50-60Hz 17/8.5-14/8 AMPS
WEIGHT (INCLUDING PACKAGING)	1500 LBS
MECHANICAL SAFETY LOCKS	AUTOMATIC ALL POSITIONS FLOOR
MECHANICAL SAFETY RELEASE	MANUAL ALL BOTH COLUMNS
SWING ARM LOCKS	AUTOMATIC LOCKING ABOVE 2 1/2" (63.5mm)
HYDRAULIC SAFETY SYSTEM	AUTOMATIC ALL POSITIONS
CYLINDERS	TWO, ONE PER COLUMN
CARRIAGE BEARINGS	EIGHT PER CARRIAGE, UHMW
SYNCHRONIZATION	EQUALIZATION CABLES



TOLERANCE UNLESS OTHERWISE SPECIFIED:				TYPICAL PRODUCTION		DL9 SPECIFICATION	
FRACTIONAL DIMENSIONS: ± 1/32" (< 12")				DO NOT SCALE DRAWING			
DECIMAL DIMENSIONS: ± .010"				UNLESS OTHERWISE SPECIFIED: ALL DIMENSIONS IN INCHES		 1 of 2 SPEC0226	
ANGULAR DIMENSIONS: ± 1°				1/32" MIN. CORNER BREAK REMOVE ALL BURRS			
WELD BEAD SIZE: 1/8" ± 0				WELD BEAD LENGTH: 1/16" ± 0		FORM ST SCALE 1:32 SHEET 1 of 2	
WELD BEAD POSITION: 3/16"				NOTES:		APPROVED DATE 10-1-2012	
D 9283 2-2-15 WRJ/CPO				000 SERIES		REVISION NUMBER	
C 8325.9 7-2-13 JC/CEL				The design and detail illustrated in this drawing is the property of Vehicle Service Group. It is being loaned with the expressed condition that it will not be duplicated or used except by permission and is subject to return upon request.		JC 10-1-2012	
B 8515 1-25-13 RJS/JU							
A 8325.1 11-16-12 ST/JC							
- 8324 10-1-12 ST/JC							
REV	CO	NUM	DATE	BY			