

MUTRADE

MUTRADE INDUSTRIAL CORP.

Hydro-Park 1127/1123

Two Post Parking Lift

Specifications

> General

Model	Hydro-Park 1127	Hydro-Park 1123
Vehicles parked per unit	2	2
Rated capacity	2700kg	2300kg
Available car length	5000mm	5000mm
Available car width	1850mm	1850mm
Available car height	2050mm	2050mm
Drive mode	Hydraulic cylinder + chains	Hydraulic cylinder + chains
Operation	Key switch	Key switch
Lifting speed	<50s	<50s
Descending speed	<35s	<35s
Power supply	100-480V, 1/3P, 50/60Hz	100-480V, 1/3P, 50/60Hz
Finishing	Powder coating with Akzo Nobel powder	Powder coating with Akzo Nobel powder

> Hydraulic

Model	Hydro-Park 1127	Hydro-Park 1123
Pump motor power	2.2Kw	2.2Kw
Pump flow	2.6ML/r	2.6ML/r
Pump working pressure	16-17MPa	16-17MPa
Hydraulic cylinder	Italian Aston seals	Italian Aston seals
Hydraulic oil	L-HV 46#	L-HV 46#
Lifting chain	LH1266	LH1266
Balance chain	LH1066	LH1066

Safety devices

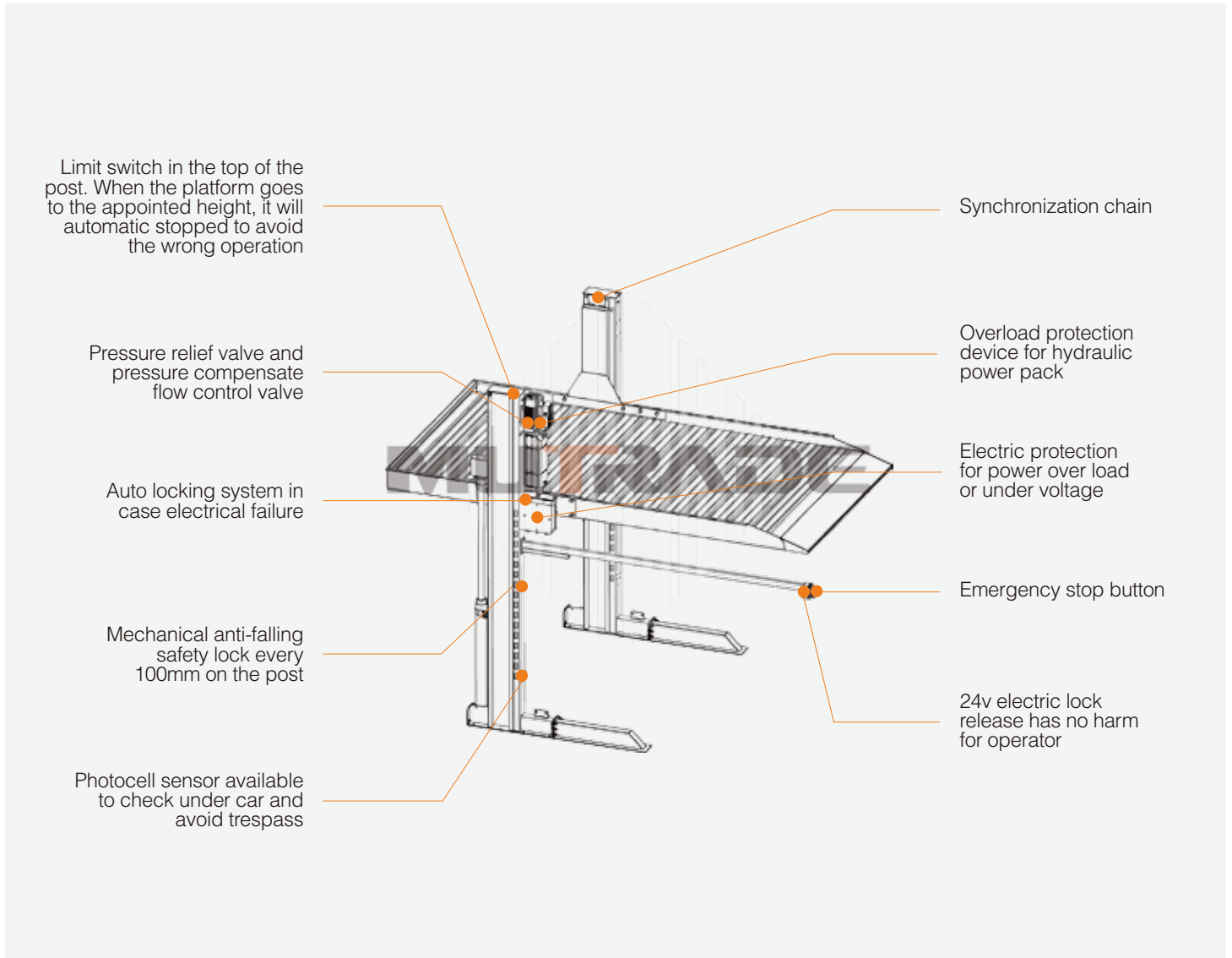

Dimensions

> Hydro-Park 1127

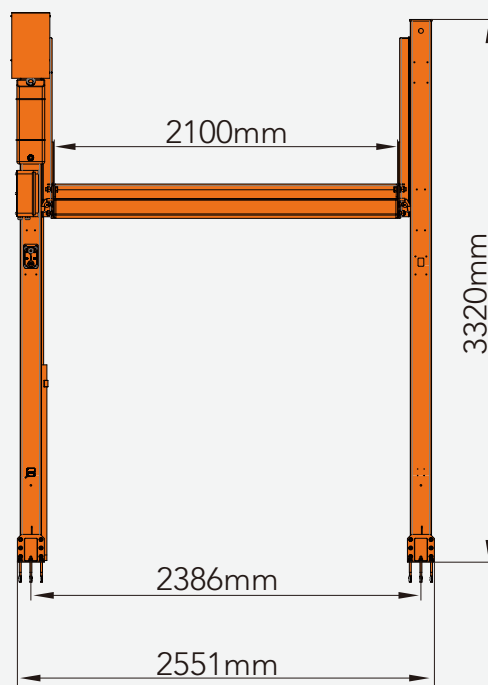
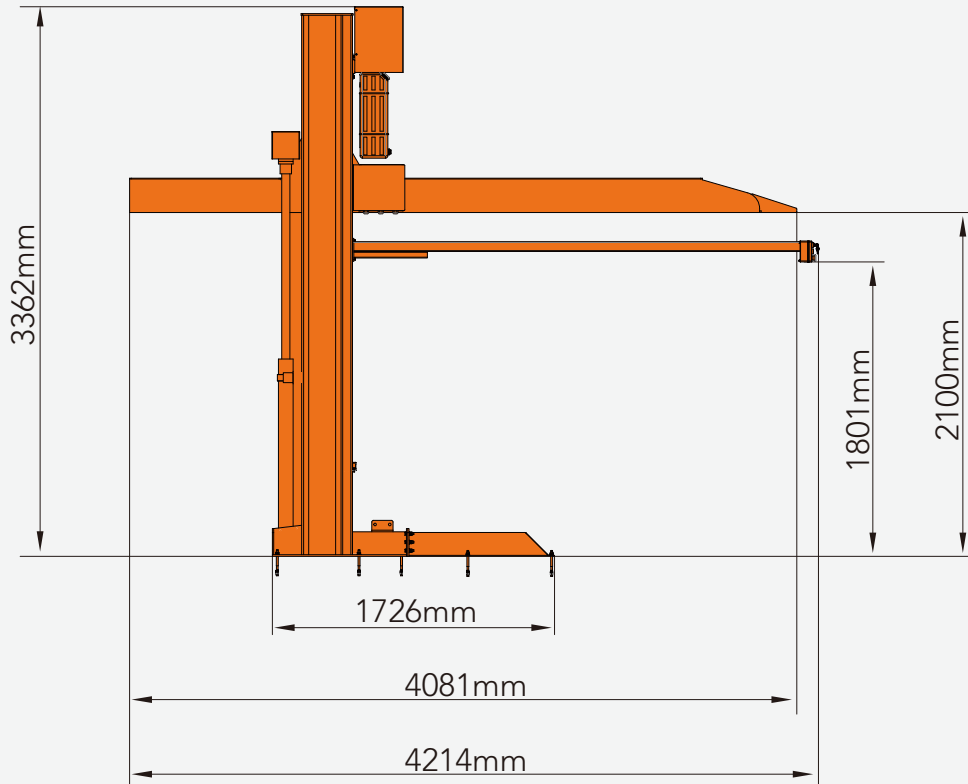

> Hydro-Park 1123

