



SPECIFICATIONS

Model	Lifting Capacity	Lifting Height	Lifting Time	Overall Height	Overall Width	Drive Thru Clearance	Width Between Columns	Minimum Pad Height	Motor
PK3.70H	3700Kg	1815 - 2044mm	52 Seconds	3621 / 3821mm	3428mm	2528mm	2850mm	115mm	2.2KW 3.0HP

FEATURES

- 3700kg Capacity
- Clear floor
- Dual hydraulic direct-drive cylinders
- Single point safety release with dual safety design
- Overhead safety shut off device
- Symmetric arm design
- Automatic arm locks
- Combination screw pads with 115mm minimum height

- Stackable adapters and hydraulic oil included
- Installation service available subject to location
- 2 Year hydraulic, electrical and mechanical warranty
- 5 Year structural warranty
- Australian Standards Certification
- Worksafe Design Registration

Tufflift Hoists Australia

Head Office 46 Saintly Drive, Truganina, VIC 3029 Phone +61 3 8375 3600
 Fax +61 3 8353 2525 Email sales@tufflift.com.au Freecall 1800 88 33 50



HOISTS FOR EVERY SPACE

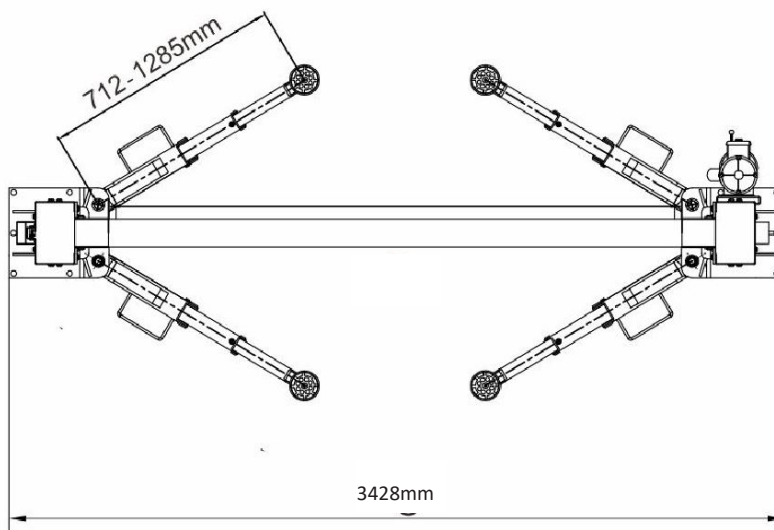
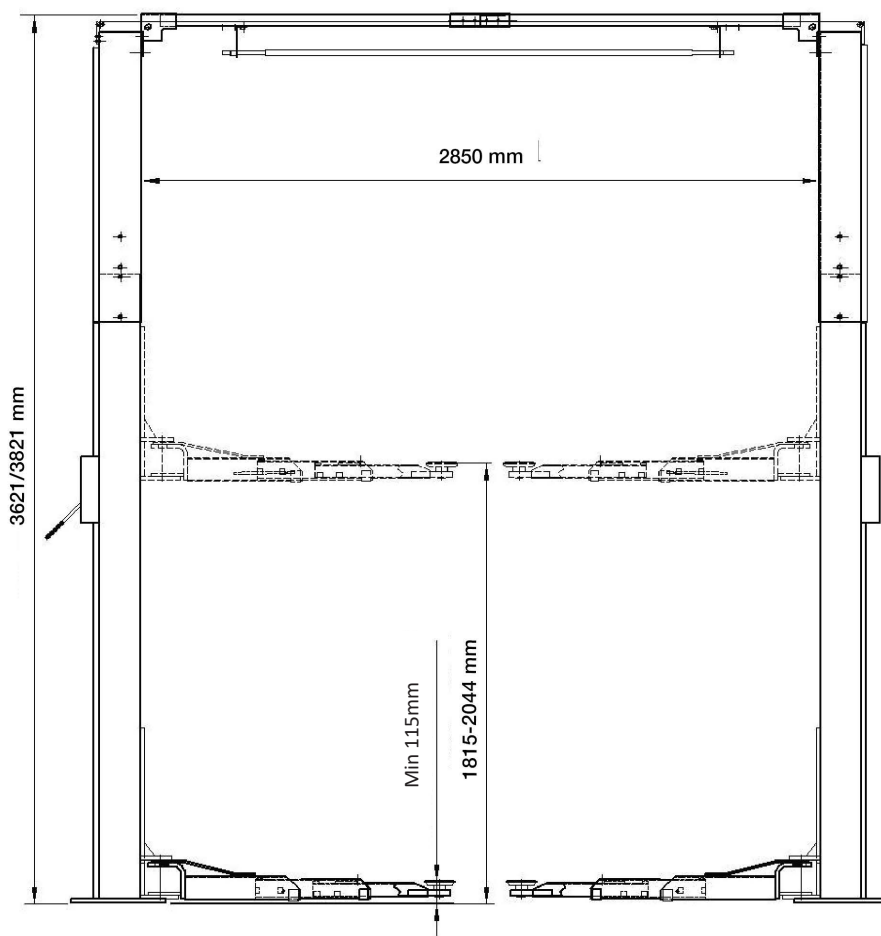

Tufflift Hoists Australia

Head Office 46 Saintly Drive, Truganina, VIC 3029 Phone +61 3 8375 3600
Fax +61 3 8353 2525 Email sales@tufflift.com.au Freecall 1800 88 33 50



HOISTS FOR EVERY SPACE