

**4500KG**  
Lifting Capacity

**One Side Operation**  
More Convenient

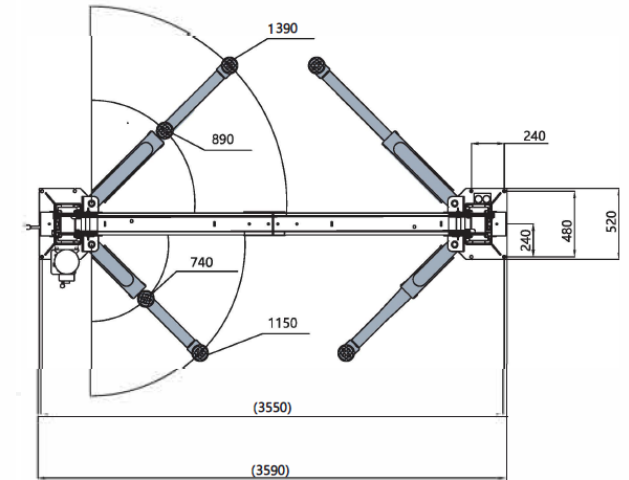

**OVERALL DIMENSION**

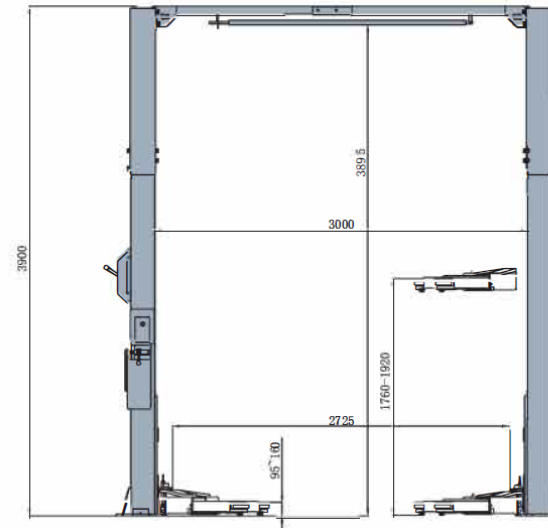

**EE-C10**

**Two Post Clear Floor Hoist**

- 4500kg Safe Working Limit.
- Single point carriage mechanical lock release.
- Cylinder straight top device run more smoothly.
- Clear Floor design allows for easy access for tools and equipment while under the vehicle.
- Durable cylinders fitted with anti-burst valves.
- Door protection pads to prevent the possibility of damage while opening the vehicle doors.
- Pre-set hydraulic pressure prevents operator overloading.
- Ram protection curtain.
- Door protection pads to prevent the possibility of damage while opening the vehicle doors.
- Durable and striking powder coat finish.
- 1900mm lifting height.
- Screw type lifting pads with minimum height of 100mm.
- The arm locks engage and disengage automatically.
- Rubber protected overhead height limit switch bar.
- Australian Standards Certification.
- WorkSafe Design Registration.

**TECHNICAL DATA**

MODEL NO.	EE-C10
Lifting capacity	4500kg
Column height	3900mm
Max lifting height	1760mm
Max lifting height with standard SUV adapters	1920mm
Min height	100mm
Lifting time	55s
Capacity of motor	2.2kW
Rated oil pressure	18Mpa
Drive through	2725mm
Weight	644kg
Electricity supply	According To Customer Needs

\*Lifting height is measured with adjustable screw pads in highest position. Machine shown with optional equipment. Actual product appearance may differ.



One Side Safety Locks Release



Pulley with Derailment Protection



Height Adapter



Round Screw-up Lifting Pad



Door Protection Pads