

## MONTY® 3550

Pneumatic tilt back post tyre changer for wheels up to 26" diameter



### MONTY® 3550

- High capability tabletop tyre changer, wheel clamping range up to 26" and tyre width up to 17".
- With optional extensions wheel clamp up to 30".
- smartSpeed driven, the innovative technology that optimises the torque applied to the wheel and automatically sets the maximum rotation speed of the wheel accordingly
- Pneumatic vertical arm for an ergonomic setup of the mount/demount head.
- High power bead breaker operated by a double-acting cylinder.
- The large shovel of the bead breaker assures care handling of the tyre always operating tangentially to the rim thanks to the 5 possibilities of adjustment.
- The standard pneumatic bead assist easymont® pro is mandatory for a correct handling of high performance tyres.
- Pedal-controlled tyre inflator with manometer comfortably positioned in the toolbox.
- Comfortable toolbox storing machine accessories and consumables.
- Self-centring four-jaw turntable operated by two cylinder, 30% more clamping force.
- The PLUS models are supplied with a kit of accessories to optimize the performances with UHP and run-flat tyres. PLUS models are WDK certified.
- GP models supplied with a top side bead seater.
- Including servicing unit, WAVE PLUS tyre lever, plastic protections for mounting head, steel roll, plastic protections for jaws, plastic rim protection, bead breaker roller board, quick exchange device for steel and plastic mounting heads



### GP models

A direct burst of compressed air facilitates bead seating. The GP models offer a top-side bead seater with a 24-litre tank.



### Bead breaker

The large shovel of the bead breaker assures care handling of the tyre always operating tangentially to the rim thanks to the 5 possibilities of adjustment.

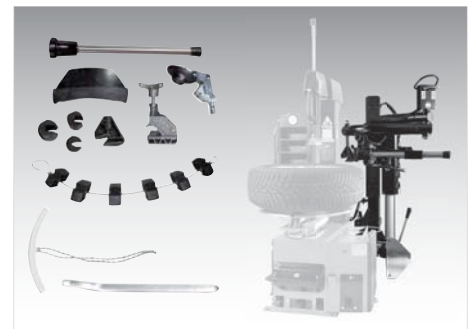















### Plus configuration

The plus models are certified by wdk. They come standard with easymont® pro and plus kit that enable the correct mounting and demounting of UHP and run-flat tyres.

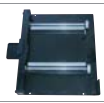

### OPTIONAL EXTRAS

	26582	Plastic protector for bead breaker blade		4029455	+4" adaptors to increase outer clamping range for monty® 3300 racing smartSpeed/GP and monty® 3300-24 smartSpeed/GP
	4026853	Plastic rim protector set (option for monty® 1270 smart, 3300-20 smart, standard on all other tyre changers)		4030649	+6" adaptors to increase outer clamping range for monty® 1270 smart, 3300-20 smart/GP and 3300-22 smartSpeed/GP
	4024784	Plastic mounting head		4027629	Light-truck adaptors 17,5" for monty® 3300 racing smartSpeed/GP and monty® 3300-24 smartSpeed/GP
	4027646	Plastic mounting head for rims with elevated spokes		4030651	Light-truck adaptors 17,5" for monty® 1270 smart, 3300-20 smart/GP and 3300-22 smartSpeed/GP
	4029337	Mounting head for motorcycle wheels (not for monty® 3550 series)		4028568	Motorcycle adaptors for monty® racing smartSpeed/GP and monty® 3300-24 smartSpeed/GP
	4028229	Quick exchange device including plastic mounting head for rims with elevated spokes		4030648	Motorcycle adaptors for monty® 1270 smart, 3300-20 smart/GP and 300-22 smartSpeed/GP
	4028629	+4" quick-exchange device including steel mounting head for monty® racing smartSpeed/GP and monty® 3300-24 smartSpeed/GP		4026290	Roller board for monty® 1270 smart up to monty® 3300 racing smartSpeed
				EAK-0279G89A	CW1015 wheel lift for monty® 3300-20 smart, 3300-22 smartSpeed, 3300-24 smartSpeed
				EAK-0279G86A	CW1025 wheel lift for monty® 3300 racing smartSpeed
				EAK-0279G87A	Wheel lift for monty® 3550

### TECHNICAL DATA

monty®		1270 smart	3300-20 smart plus/GP	3300-22 smartSpeed/GP plus	3300-24 smartSpeed/GP plus	3300 racing smartSpeed/GP plus	3550
Inner clamping range	inch	12-22	12-22	12-24	12-24	12-24	14-26
Outer clamping range	inch	10-20	10-20	10-22	10-24	10-24	12-26
Rim width	inch	3-11	3-12	3-12	3-12	3-14	3-16
Max. tyre width	inch	12	13	13	13	15	17
Max. wheel diameter	mm	1000	1000	1000	1000	1000	1200
Speed	rpm	7	7	7 / 7-18	7 / 7-18	7 / 7-18	7/7-20
Bead breaking range	mm	70-340	70-340	40-392	40-392	40-392	70-410
Compressed air supply	bar	8-12	8-12	8-12	8-12	8-12	8-12
Dimensions (W x D x H)	mm	1150x1030x1730	1160x1700x1850	1300x1700x1860	1220x1700x1870	1350x1800x1920	1850x1960x2270
Weight	kg	173	300	300	310	315	485
Power supply		400 V 3ph 50 Hz	400 V 3ph 50 Hz	230 V 1ph 50-60 Hz	230 V 1ph 50-60 Hz	230 V 1ph 50-60 Hz	230 V 1ph 50-60 Hz

**EMEA-JA**  
Snap-on Equipment s.r.l. - Via Prov. Carpi, 33 - 42015 Correggio (RE)  
Phone: +39 0522 733-411 - Fax: +39 0522 733-479 - www.hofmann-equipment.com

**Austria**  
Snap-on Equipment Austria GmbH - Hauptstrasse 24/Top 14 - A-2880 St. Corona/Wechsel (RE)  
Phone: +43 1 865 97 84 - Fax: +43 1 865 97 84 29 - www.hofmann-equipment.com

**France**  
Snap-on Equipment France - ZA du Vert Galant - 15, rue de la Guivernone BP 97175  
Saint-Ouen-l'Aumône - 95056 Cergy-Pontoise CEDEX  
Phone: +33 134 48 58-78 - Fax: +33 134 48 58-70 - www.hofmann-equipment.com

**Germany**  
Snap-on Equipment GmbH - Konrad-Zuse-Straße 1 - 84579 Unterneukirchen  
Phone: +49 8634 622-0 - Fax: +49 8634 5501 - www.hofmann-equipment.com

**Italy**  
Snap-on Equipment s.r.l. - Via Prov. Carpi, 33 - 42015 Correggio (RE)  
Phone: +39 0522 733-411 - Fax: +39 0522 733-410 - www.hofmann-equipment.com

**United Kingdom**  
Snap-on Equipment Ltd. - Unit 17 Denney Road, King's Lynn - Norfolk PE30 4HG  
Phone: +44 118 929-6811 - Fax: +44 118 966-4369 - www.hofmann-equipment.com