

**4000KG/4500KG**  
Lifting Capacity

**One Side Operation**  
More Convenient

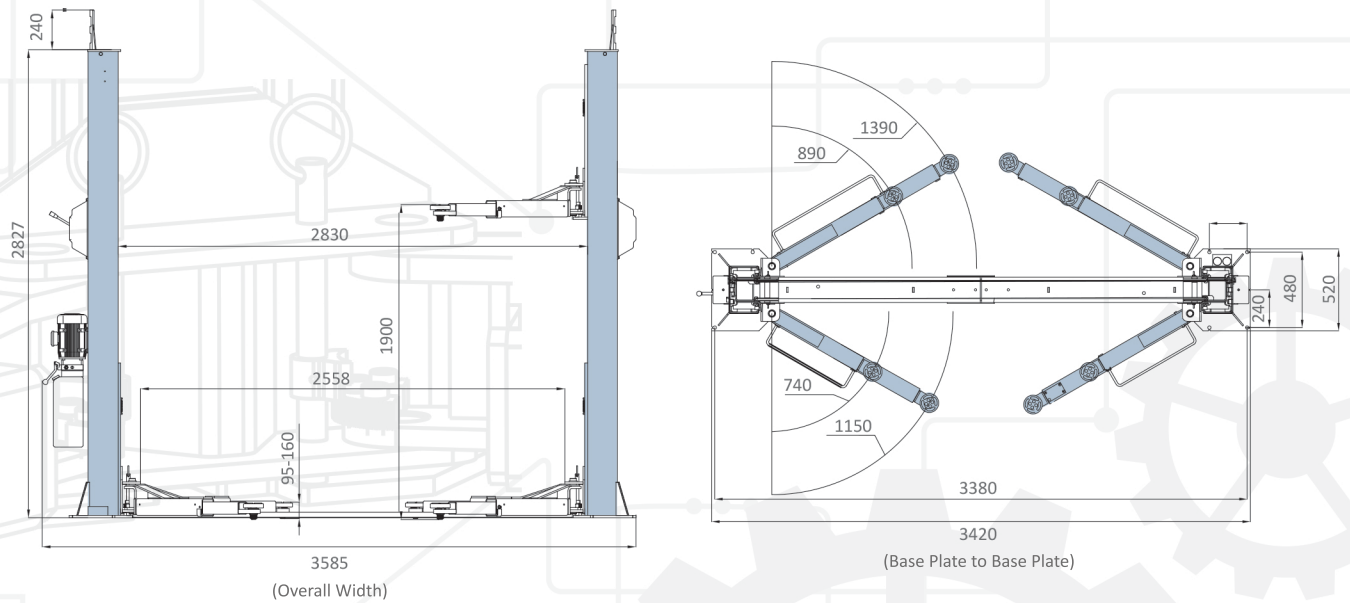

**OVERALL DIMENSION**



**TECHNICAL DATA**

MODEL NO.	EE-F9	EE-F10
Lifting capacity	4000kg	4500kg
Max lifting height	1900mm	1900mm
Min height	95mm-160mm	95mm-160mm
Lifting time	65S	65S
Capacity of motor	2.2kW	2.2kW
Rated oil pressure	18MPa	22MPa
Drive through	2830mm	2830mm
Overall Height	2827mm+240mm	2827mm+240mm
Drive through clearance (wheels)	2558mm	2558mm
Width Between Columns (body)	2830mm	2830mm
Electricity supply	According To Customer Needs	According To Customer Needs



One Side Safety Locks Release



Door Protection Pads



**EE-F9/F10**

**TWO POST LIFT**

- 4000kg/4500kg lifting capacity.
- Single side release for mechanical safety locking unit.
- Durable cylinders in each column carry with anti-surge valves.
- Standard door protection pads to prevent possible damage to the door opened without caution.
- Pre-fixed hydraulic pressure prevents overloading operation.
- Standard chain protection curtain.

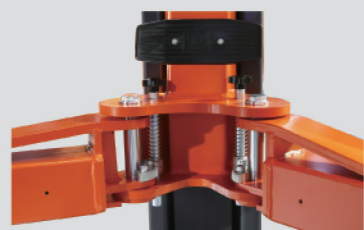

Strong Carriage and Arm Structure

\* Max. Lifting height is measured with adjustable screw pads in highest position  
\* Machine shown with optional equipment. Actual product appearance may differ