

EE-6501

3.0 Ton Full Rise Scissor Lift - Electronic Controls (Directional)



- » 3.0 Ton lifting capacity
- » Ideal for workshops where space is limited
- » Minimum height 110mm
- » Durable charcoal Hammertone powder coat finish platforms, with orange scissor
- » Aluminium power unit
- » Surface mount
- » Pneumatic lock release
- » Four cylinder design
- » Height limit switch
- » Drive on ramps and platform extensions lock into position
- » Certified to Australian Standards and design registered with Worksafe
- » Self-lubricating bushes and bearings
- » 2 Years parts & labour warranty

INCLUSIONS

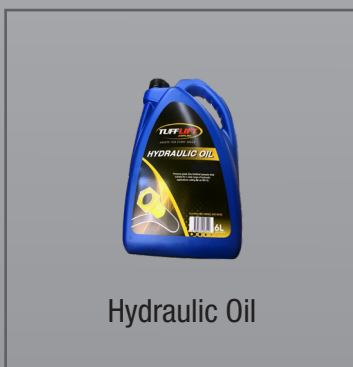

OPTIONS

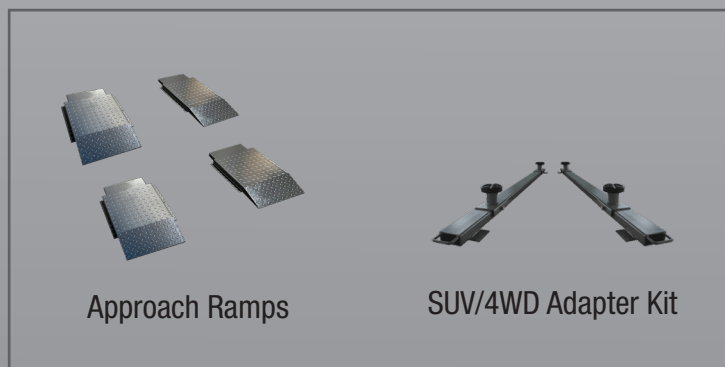

EE-6501

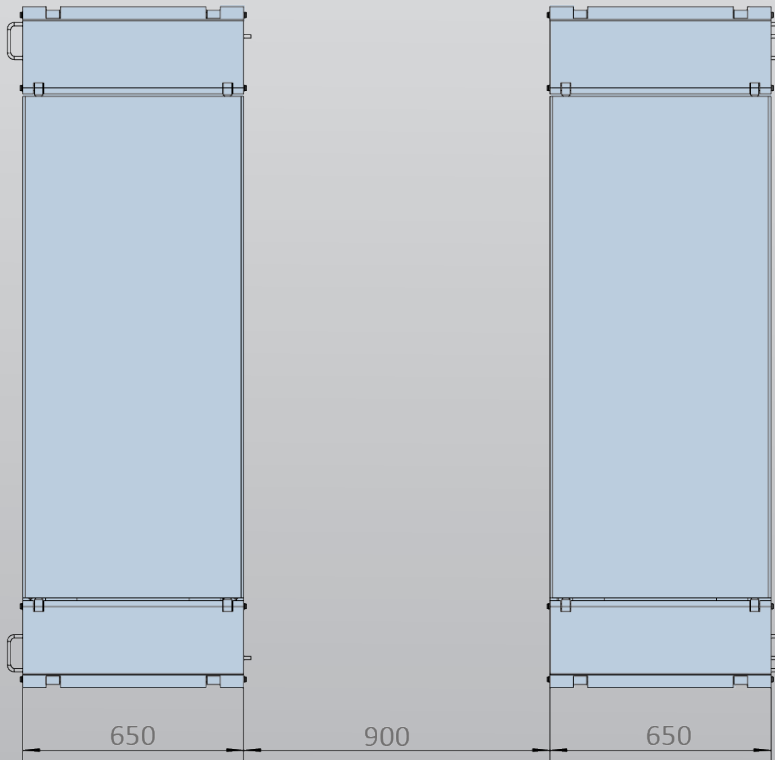

Minimum Concrete Requirement
150mm
Power Requirements
240v
2.2kw 16 amps
3 phase
2.2kw 5amps
No neutral required
Freight Dimensions
205 x 70 x 100cm
900kg

