

EE-MR35

3.5 Ton Mid Rise Scissor Lift - Electronic Controls (Directional)



- » 3.5 Ton lifting capacity
- » Ideal for narrow workshops, tyre shops, low ceiling height, car detailers, sign writers
- » Full electronic controls
- » Durable charcoal Hammertone powder coat finish platforms, with orange scissor
- » Mechanical safety lock, Electric release
- » Aluminium power unit
- » Start up plate
- » Drive on ramps and platform extensions lock into position
- » Self-lubricating bushes and bearings
- » Two different height lifting rubber blocks
- » Certified to Australian Standards and design registered with Worksafe
- » 2 Years parts & labour warranty

INCLUSIONS



Hydraulic Oil

OPTIONS

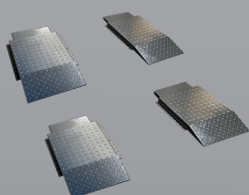

Approach Ramps



Mobile Kit



SUV/4WD Adapter Kit

EE-MR35

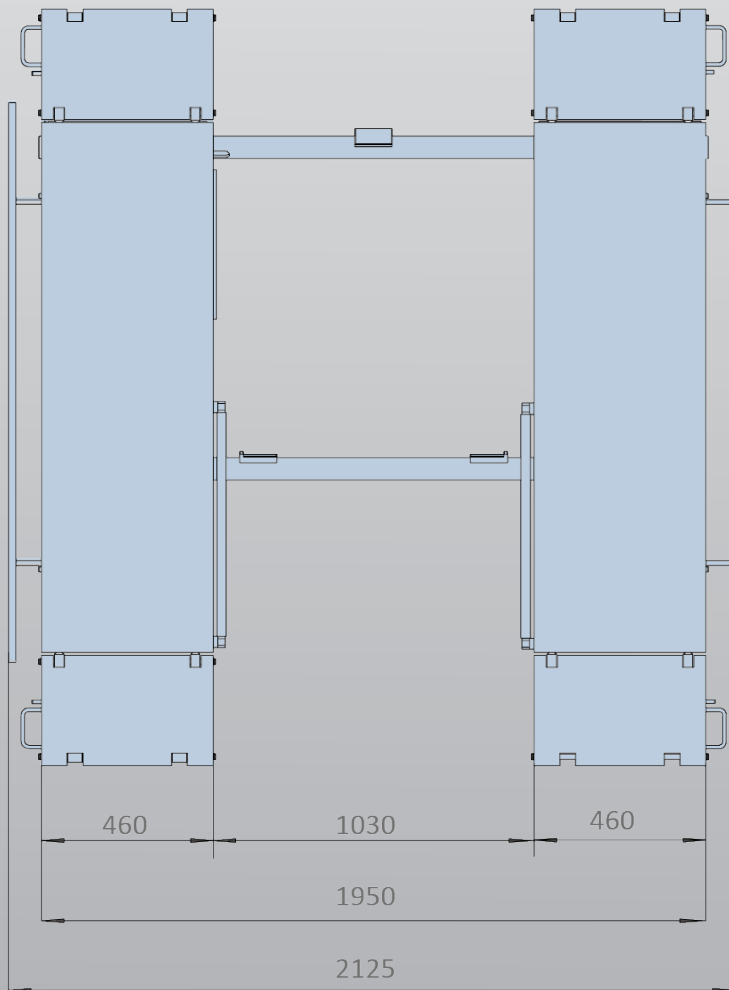

Minimum Concrete Requirement
115mm
Power Requirements
240v
2.2kw 16 amps
No neutral required
Freight Dimensions
199 x 160 x 60cm
629kg

