

# EE-F9

## 4.0 Ton 2 Post Base Plate Hoist

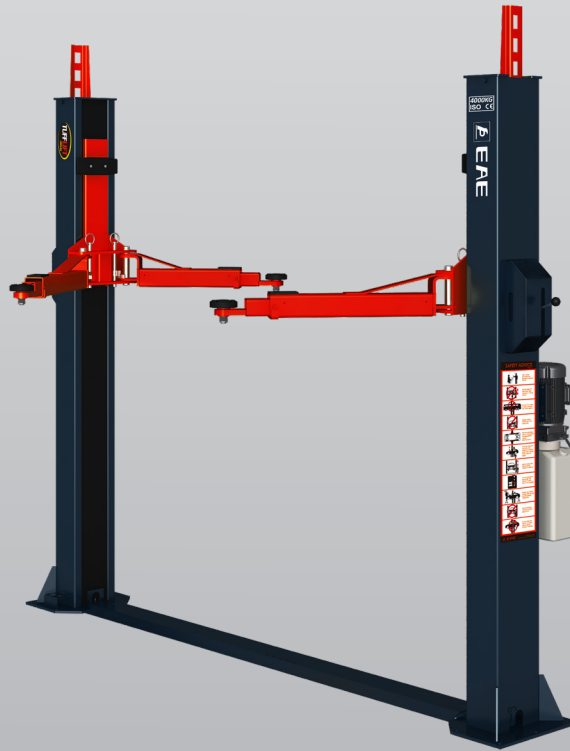

- » 4.0 Ton lifting capacity
- » Lifting height of 1.90m plus 4WD adapters
- » Base plate design
- » Durable charcoal Hammertone powder coat finish, with orange arms
- » Single lock release
- » Door protection pads
- » Combination screw pads plus 4WD adapters
- » 5 Years Structural, 1 Year electrical, parts & labour warranty
- » Certified to Australian Standards and design registered with Worksafe
- » Optional EV charging station

### INCLUSIONS



Hydraulic Oil



Screw Pad /  
4WD Adapter

### OPTIONS



EV Charging Station



Tyre Holder Adapter

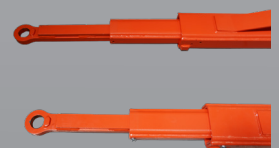

EAE Low Profile Arm

# EE-F9

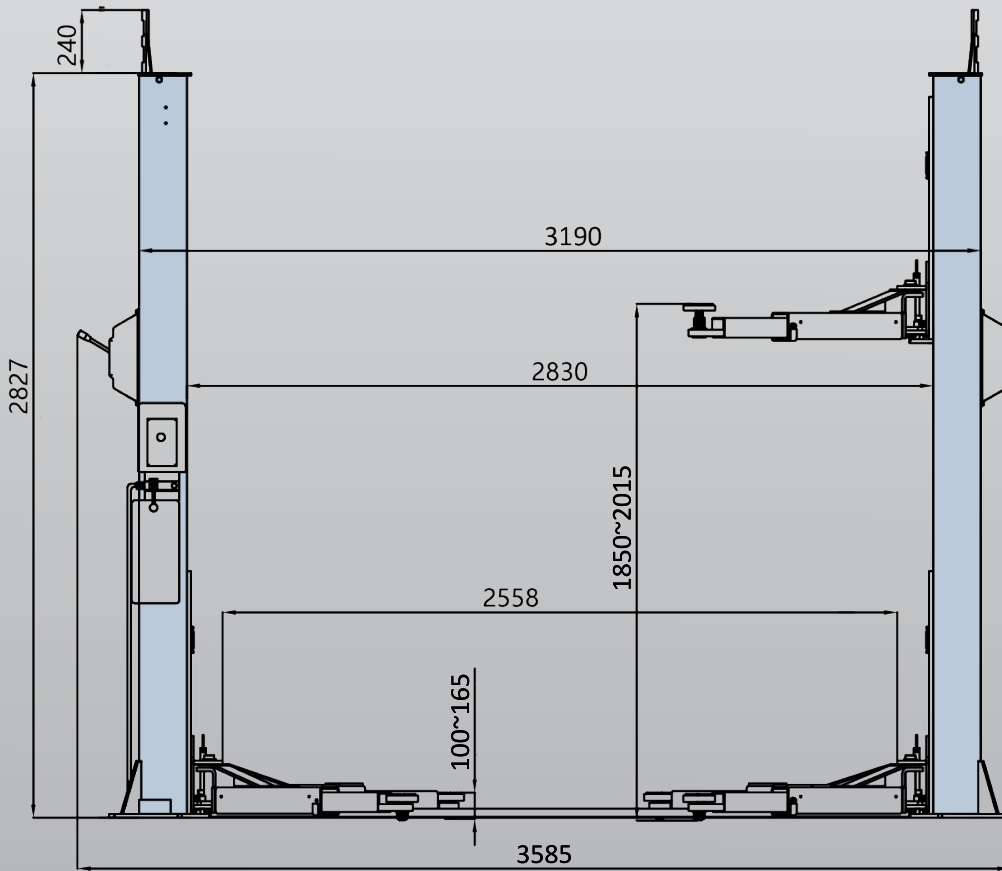

<b>Minimum Concrete Requirement</b>
115mm
<b>Recommended Ceiling Height</b>
3.25m
<b>Power Requirements</b>
240v
2.2kw 16 amps
3 phase
3.5kw 9 amps
Fast motor
Neutral required
<b>Freight Dimensions</b>
286 x 57 x 100cm
672kg

