

TL.60MH

600kg Electric Over Hydraulic Motorcycle Hoist



- » 600KG Lifting capacity
- » Electric hydraulic control
- » Manual lock release
- » Skid proof diamond plated platform
- » Removeable rear cover is convenient for rear wheel changing
- » Quick removable approach ramps
- » Includes adjustable wheel vice to extend axle base up to 410 mm
- » Automatic safety lock activation

OPTIONS

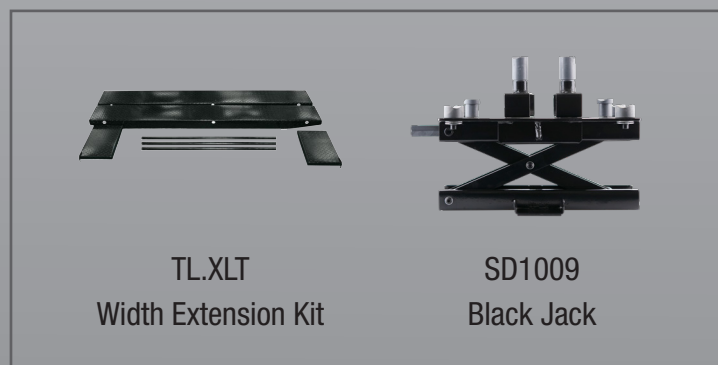

TL.XLT
Width Extension Kit

SD1009
Black Jack

TL.60MH

Freight Dimensions

230 x 71 x 82cm
300kg

Power Requirements

240v 13amps

