

TL3.5PH

3.5 Ton High Position Four Post



» 3.5 Ton lifting capacity

» Lifting height of 3.7m

» Double your parking space

» Pneumatic lock release

» Perfect for storing higher vehicles (eg. Winnebago's RV's) or accessing a mezzanine level.

» Cable slack locks

» Anti-surge valve

» Mechanically locks each interval

» 5 years (structure) and 1 year (electrical and hydraulics)

INCLUSIONS



Hydraulic Oil

OPTIONS



Rolling Jack Air Pump

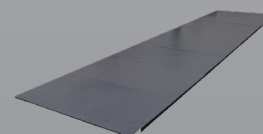

Infill Kit

TL3.5PH

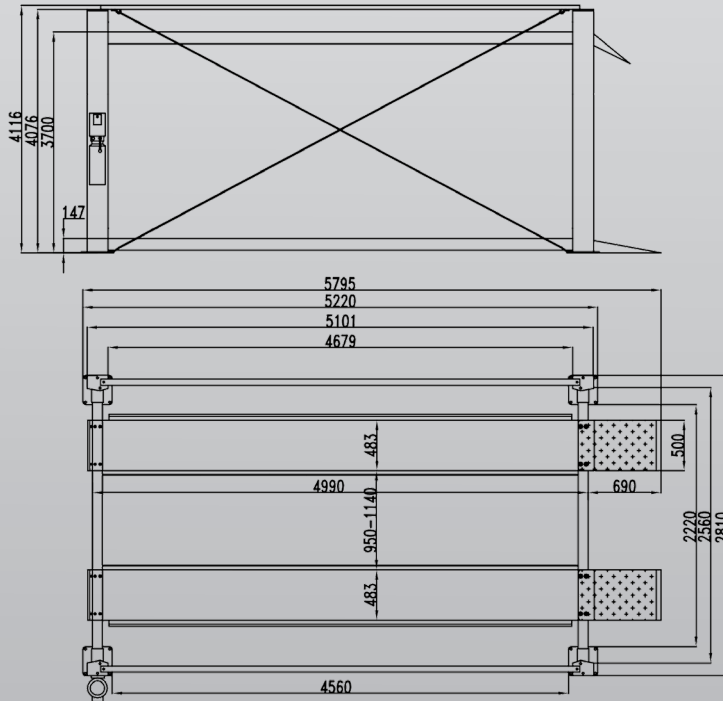

Minimum Concrete Requirement

150mm

Recommended Ceiling Height

Subject to vehicle height

Power Requirements

240v

15 amps

Freight Dimensions

425 x 57 x 110cm

1400kg

