

TLM-3TPH

4 Post 3 Tier Parking Hoist



- » Lifting capacity:
2nd floor - 2500kg, 3rd floor - 2000kg
- » Electric park button
- » Electric lock release
- » Single electrical connection point
- » Factory wired control box
- » Extended lock ladders (more parking position options)
- » Hydraulic system anti burst valve
- » Full metal deck inserts for maximum vehicle protection
- » Secondary isolation switch
- » Height limit switches
- » Durable charcoal Hammertone powder coat finish
- » 5 Years structural, 1 Year electrical parts & labour warranty
- » Certified to Australian Standards and design registered with Worksafe

INCLUSIONS



Hydraulic Oil



Wheel Stops

Metal Deck Inserts

INCLUSIONS

Longer Aluminium Ramps

TLM-3TPH

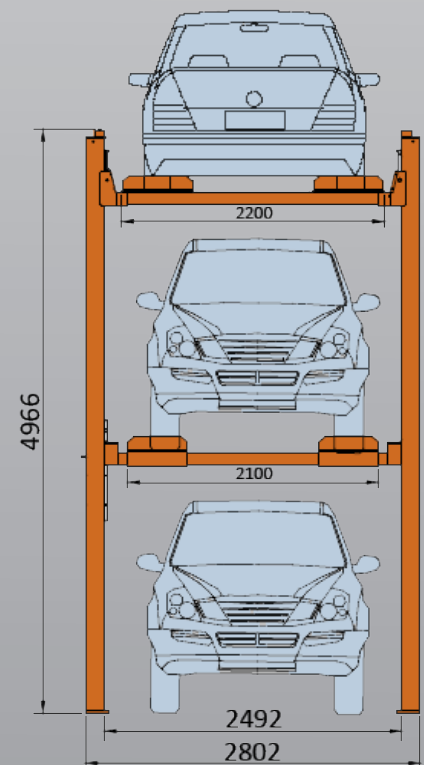
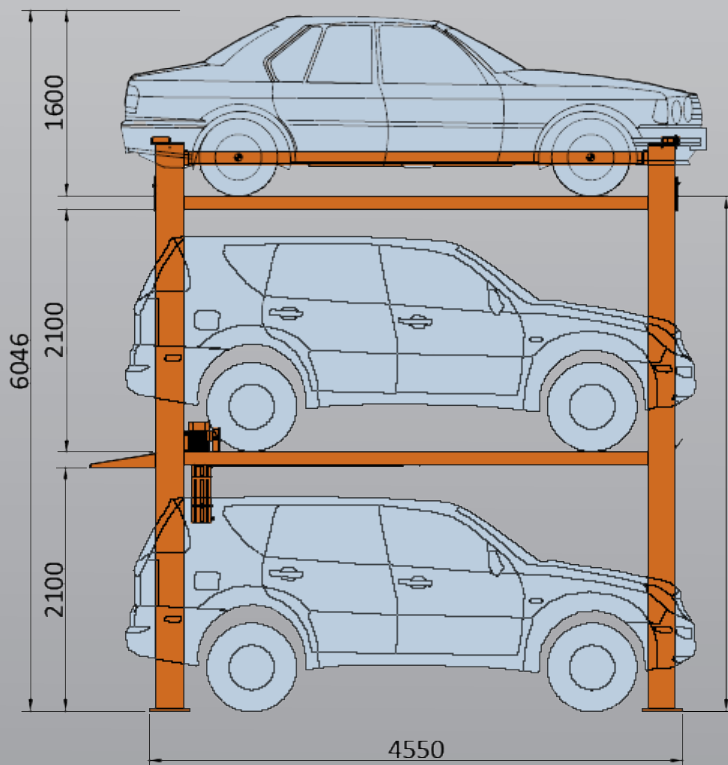
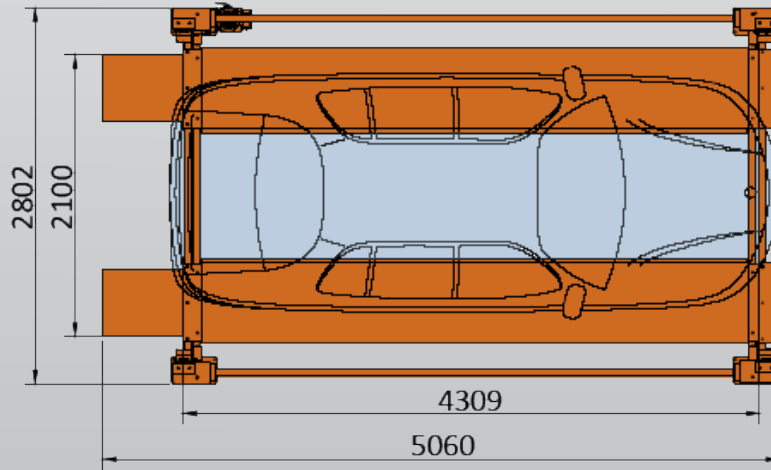

Power Requirements
240v
3kw 16.5amps

Minimum Concrete Requirement
150mm

Recommended Ceiling Height
>6.1m

Freight Dimensions
495 x 75 x 107cm
2000kg