

EE-6215EKZ

5.0 Ton 4.3m High 2 Post Clear Floor Hoist Asymmetric Columns - Electronic Controls

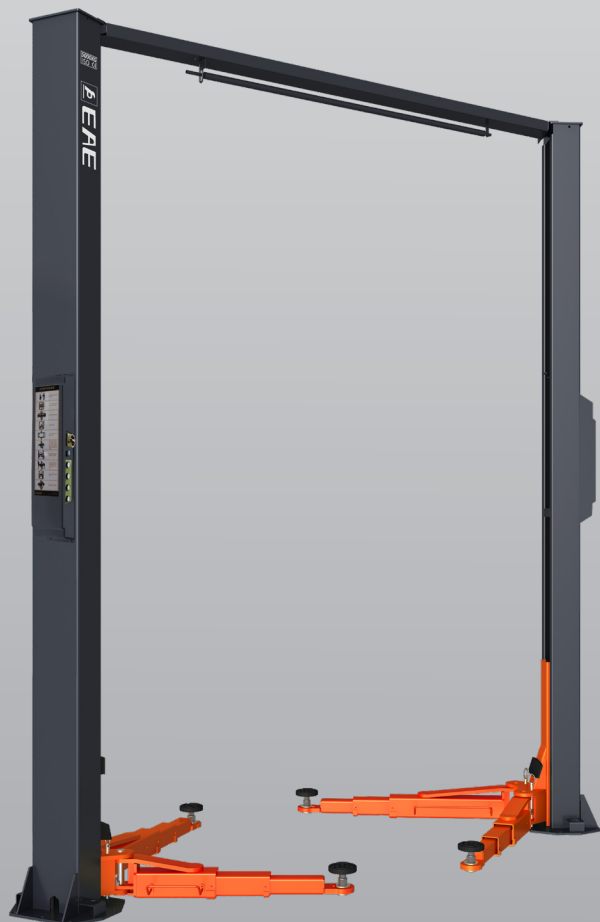

- » 5.0 Ton lifting capacity
- » Lifting height of 1.97m plus 4WD adapters
- » Clear floor design
- » Screw-up lifting pads with clearance height less than 100mm
- » Durable charcoal Hammertone powder coat finish, with orange arms
- » 30 degree of columns installation leaves more space for opening the door
- » 4 triple stage arms accomodates a wide range of vehicles, from smart to sprinter and light vans
- » Durable cylinders in each column carry with anti surge valves
- » Electrical release
- » Asymmetric columns
- » Standard column curtain
- » ABS control box with rubber gasket sealing
- » 5 Years Structural, 2 Years electrical, parts & labour warranty
- » Certified to Australian Standards and design registered with Worksafe

INCLUSIONS



OPTIONS



EE-6215EKZ

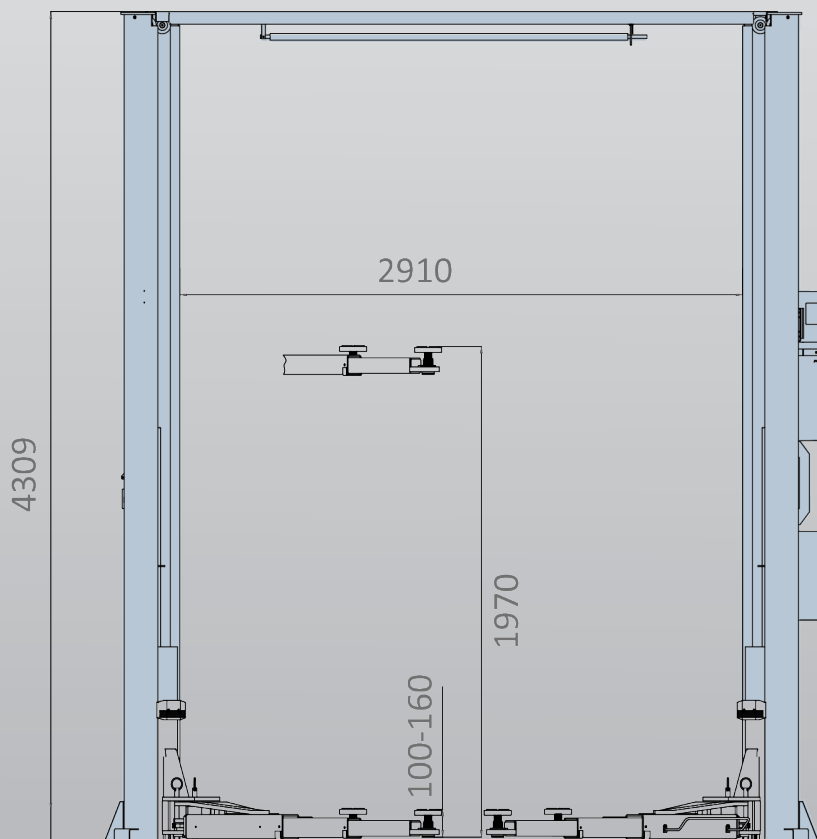

Minimum Concrete Requirement

125mm

Recommended Ceiling Height

4.6m

Power Requirements

3 phase

3.5kw 9 amps

Fast motor

No neutral required

Freight Dimensions

433 x 57 x 93cm

895kg

