

# EE-6501V3

## 3.0 Ton Full Rise Scissor Lift - Electronic Controls (Directional)



» 3.5 Ton lifting capacity

» Ideal for workshops where space is limited

» Minimum height 105mm

» Durable charcoal Hammertone powder coat finish platforms, with orange scissor

» Aluminium power unit

» Surface mount

» Pneumatic lock release

» Four cylinder design

» Height limit switch

» Drive on ramps and platform extensions lock into position

» Self-lubricating bushes and bearings

» 5 Year structural, 2 years electrical, parts & labour warranty

» Certified to Australian Standards and design registered with Worksafe

### INCLUSIONS



Hydraulic Oil

Rubber Pads

### OPTIONS

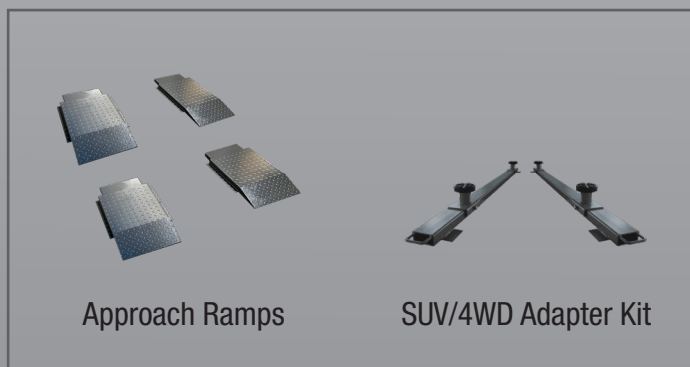

Approach Ramps

SUV/4WD Adapter Kit

# EE-6501V3

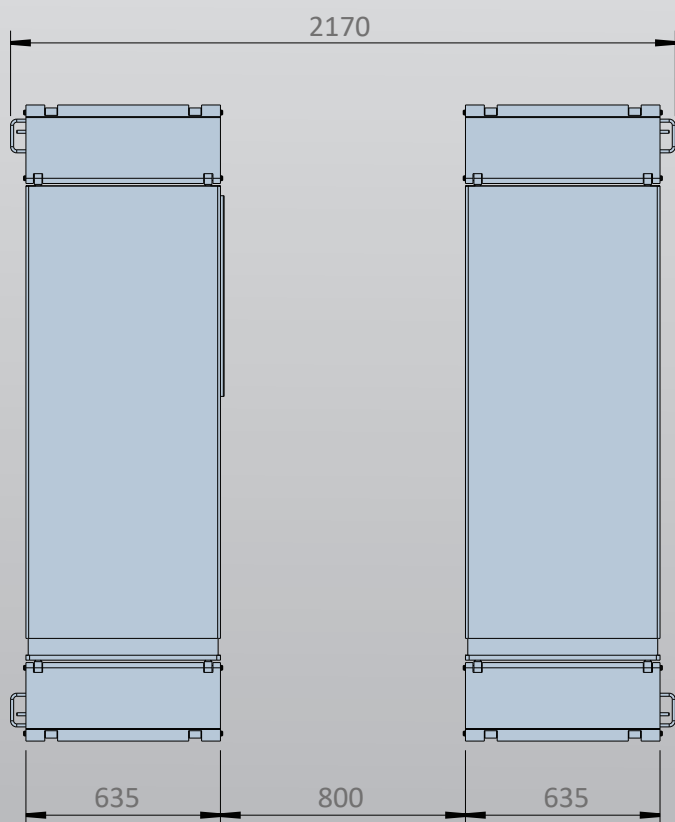

**Minimum Concrete Requirement**

150mm

**Power Requirements**

240v

2.2kw 16 amps

3 phase

2.2kw 5amps

No neutral required

**Freight Dimensions**

205 x 70 x 100cm

900kg

