

EE-F10

4.5 Ton 2 Post Base Plate Hoist

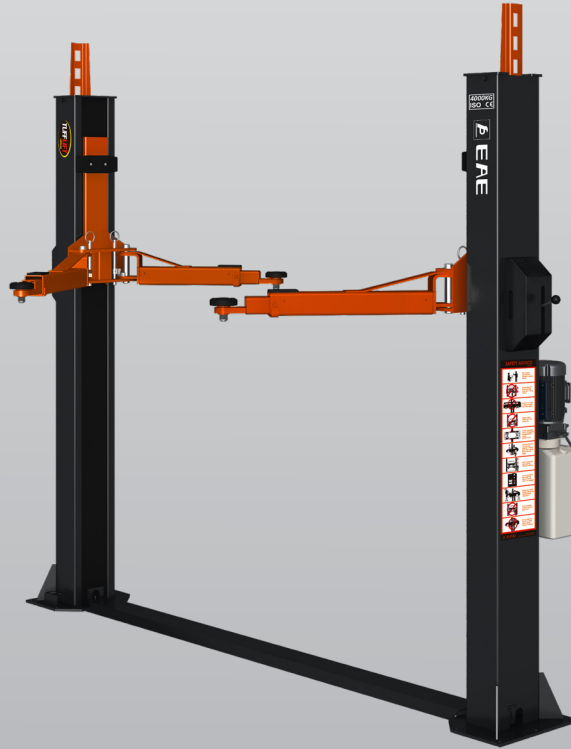

» 4.5 Ton lifting capacity

» Lifting height of 1.85m plus 4WD adapters

» Base plate design

» Durable charcoal Hammertone powder coat finish, with orange arms

» Single lock release

» Door protection pads

» Combination screw pads plus 4WD adapters

» 5 Years Structural, 1 Year electrical, parts & labour warranty

» Certified to Australian Standards and design registered with Worksafe

INCLUSIONS



Hydraulic Oil



Screw Pad /
4WD Adapter



Arm Tool Tray

OPTIONS



EV Charging Station



Tyre Holder Adapter

EE-F10

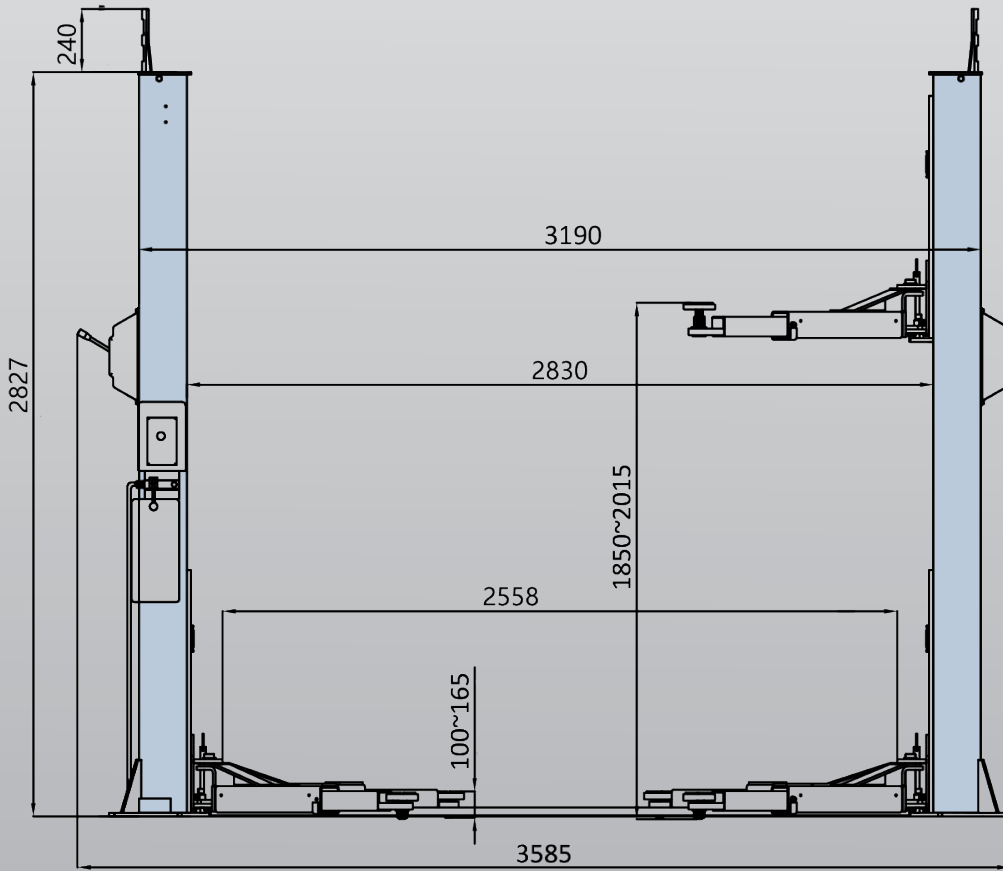

Minimum Concrete Requirement
150mm
Recommended Ceiling Height
3.25m
Power Requirements
240v
2.2kw 16 amps
3 phase
3.5kw 9 amps
Fast motor
Neutral required
Freight Dimensions
290 x 56 x 110cm
730kg

