

TLV5.50H

5.5 Ton 2 Post Clear Floor Hoist



- » 5.5 Ton lifting capacity
- » Lifting height of 1.85m plus 4WD adapters
- » Clear floor design
- » Durable charcoal powder coat finish, with orange arms
- » Spring operated arm restraints
- » Mechanical lock release
- » Rubber protected height limit switch bar
- » 3 Stage symmetric arms
- » Anti-surge valve
- » 5 Years Structural, 1 Year electrical, parts & labour warranty
- » Certified to Australian Standards and design registered with Worksafe

INCLUSIONS



OPTIONS

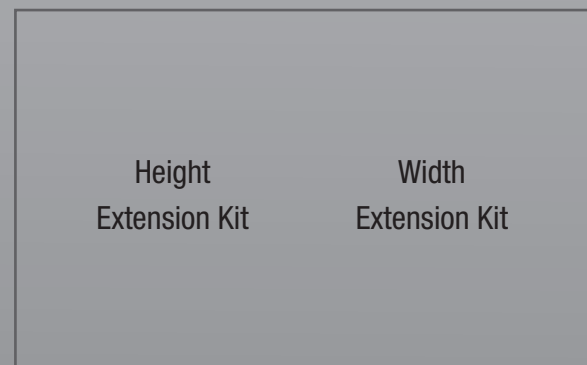

TLV5.50H

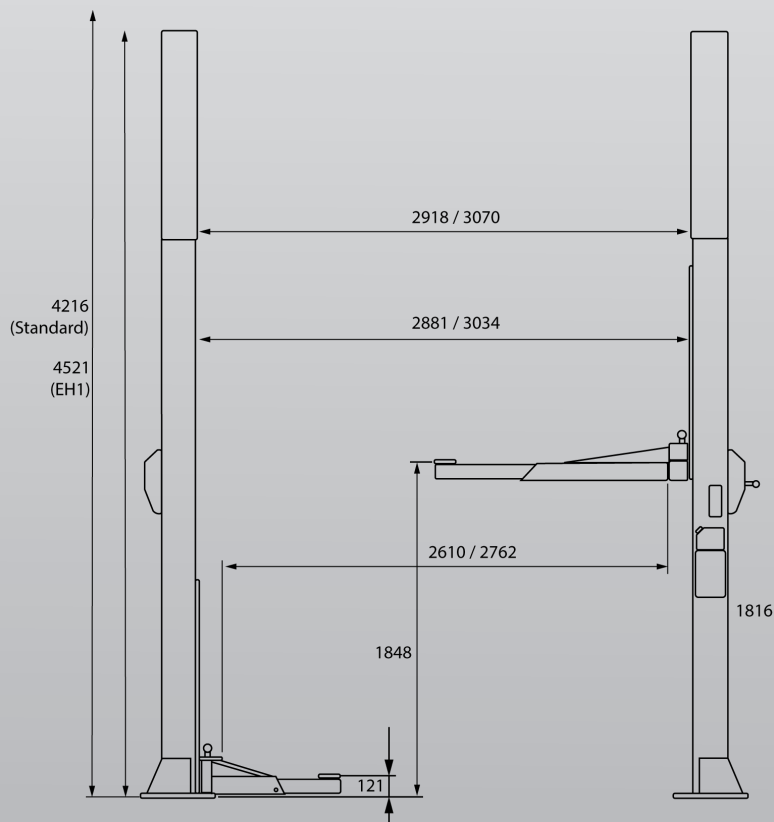

Minimum Concrete Requirement
110mm
Recommended Ceiling Height
4.4m
Power Requirements
240v
3kw 17 amps
3 phase
3kw 8.5 amps
Freight Dimensions
350 x 54 x 110cm
950kg

